

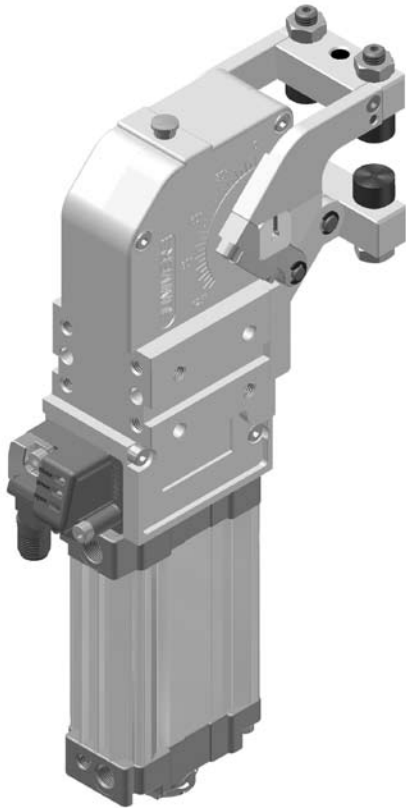

UGP Series Pneumatic Gripper



Features

- Single and Double Moving Jaws
- Single and Double Tips
- Fully Adjustable opening angle
- Opening angle can be set with or without air pressure
- Linear and rotary motion guided by roller bearings
- Remains locked in closed position even when air pressure is removed
- Pneumatic ports on both sides of the cylinder
- Manual release button to open mechanism when air pressure is removed
- Unique “programmable” all metal sensor with M12 swivel connector

General Specifications

Weight:

UGP40: 1.8 Kg (4.0 lbs)

Operating Pressure:

Minimum: 2.75 Bar (40 PSI)

Maximum: 8 Bar (115 PSI)

Operating Temperature: 5° to 45° C (40° to 113°F)

Class Protection: IP65

Opening Angles:

UGP40VB: Adjustable from 0° to 77°

UGP40VF: Adjustable from 0° to 77°

UGP40VL: Adjustable from 0° to 95°

UGP40OL: Adjustable from 0° to 53°

See dimensional drawings for more information

Holding Capacity: 600Nm (5310 in-lbs)

Maximum Grip Force

Model Number	4 Bar (58 PSI)	5 Bar (72 PSI)
UGP40V	1900 N (427 lbs)	2333 N (524 lbs)
UGP40O	1500 N (337 lbs)	1866 N (419 lbs)

How to Order

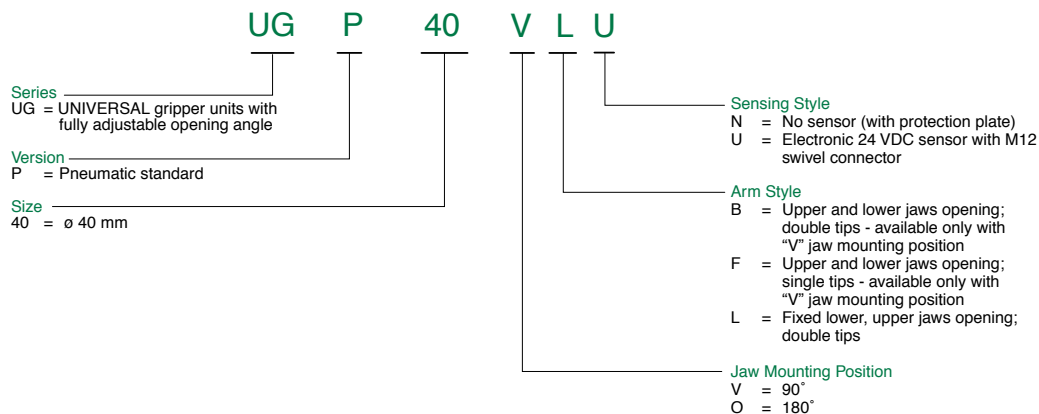



UGP Series Pneumatic Gripper

UGP40VBU Pneumatic Gripper

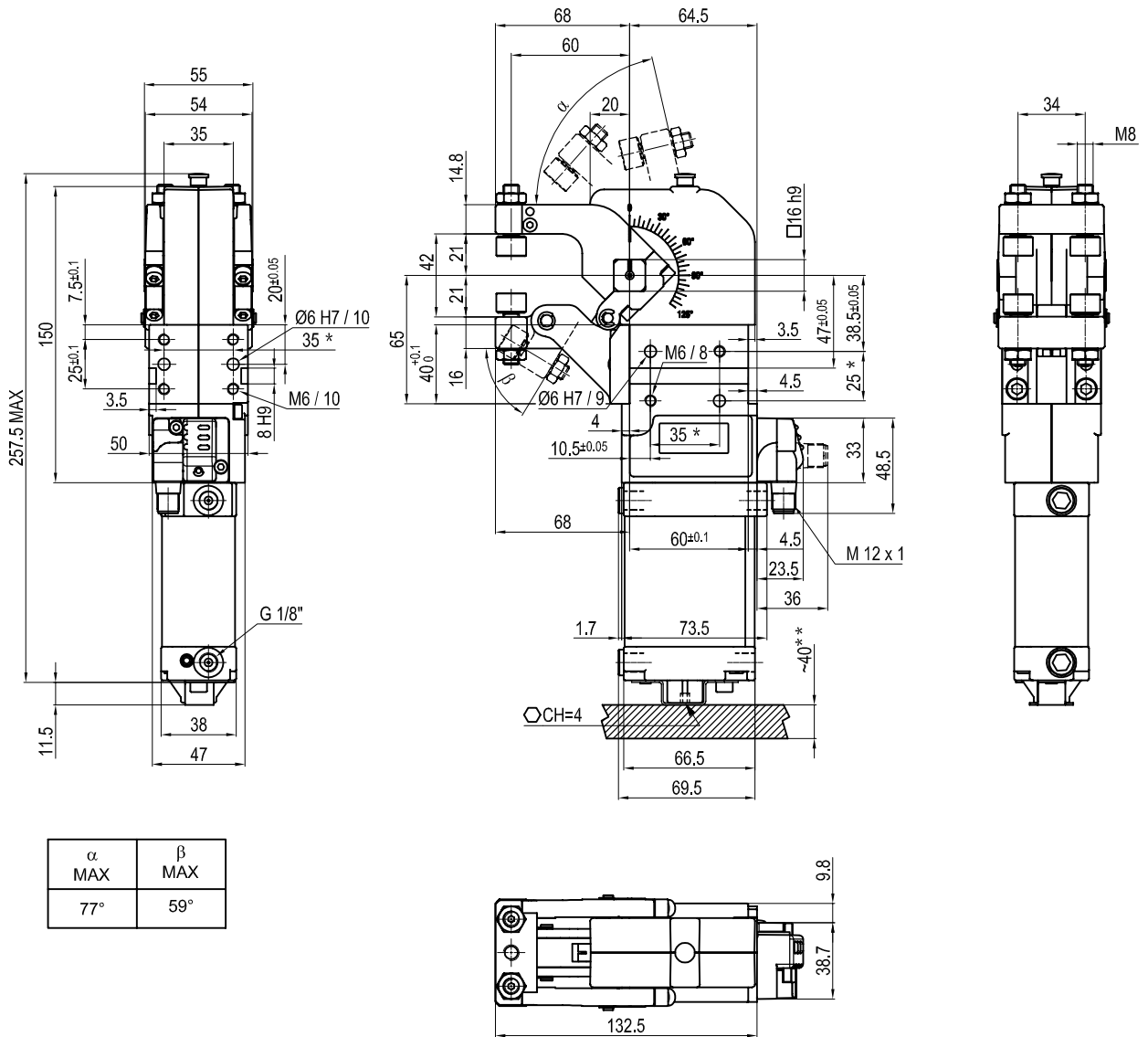

α MAX	β MAX
77°	59°

* : TOLERANCE BETWEEN DOWELS ± 0.02 , TO SCREW HOLES ± 0.1

** : AREA TO ACCESS ANGLE ADJUSTMENT



UGP Series Pneumatic Gripper

UGP40VFU Pneumatic Gripper

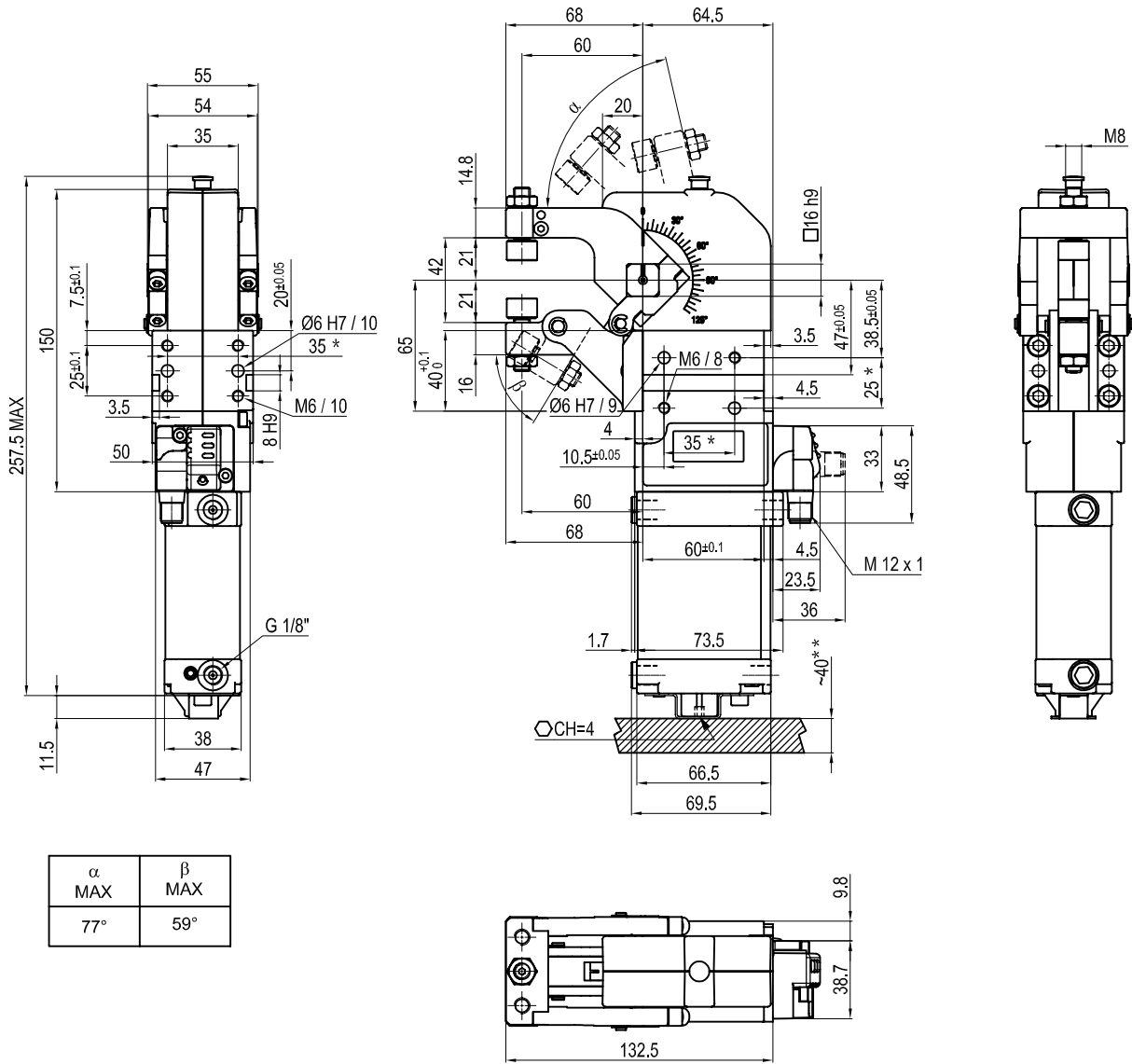

α MAX	β MAX
77°	59°

* : TOLERANCE BETWEEN DOWELS ± 0.02 , TO SCREW HOLES ± 0.1

** : AREA TO ACCESS ANGLE ADJUSTMENT



UGP Series Pneumatic Gripper

UGP40VLU Pneumatic Gripper

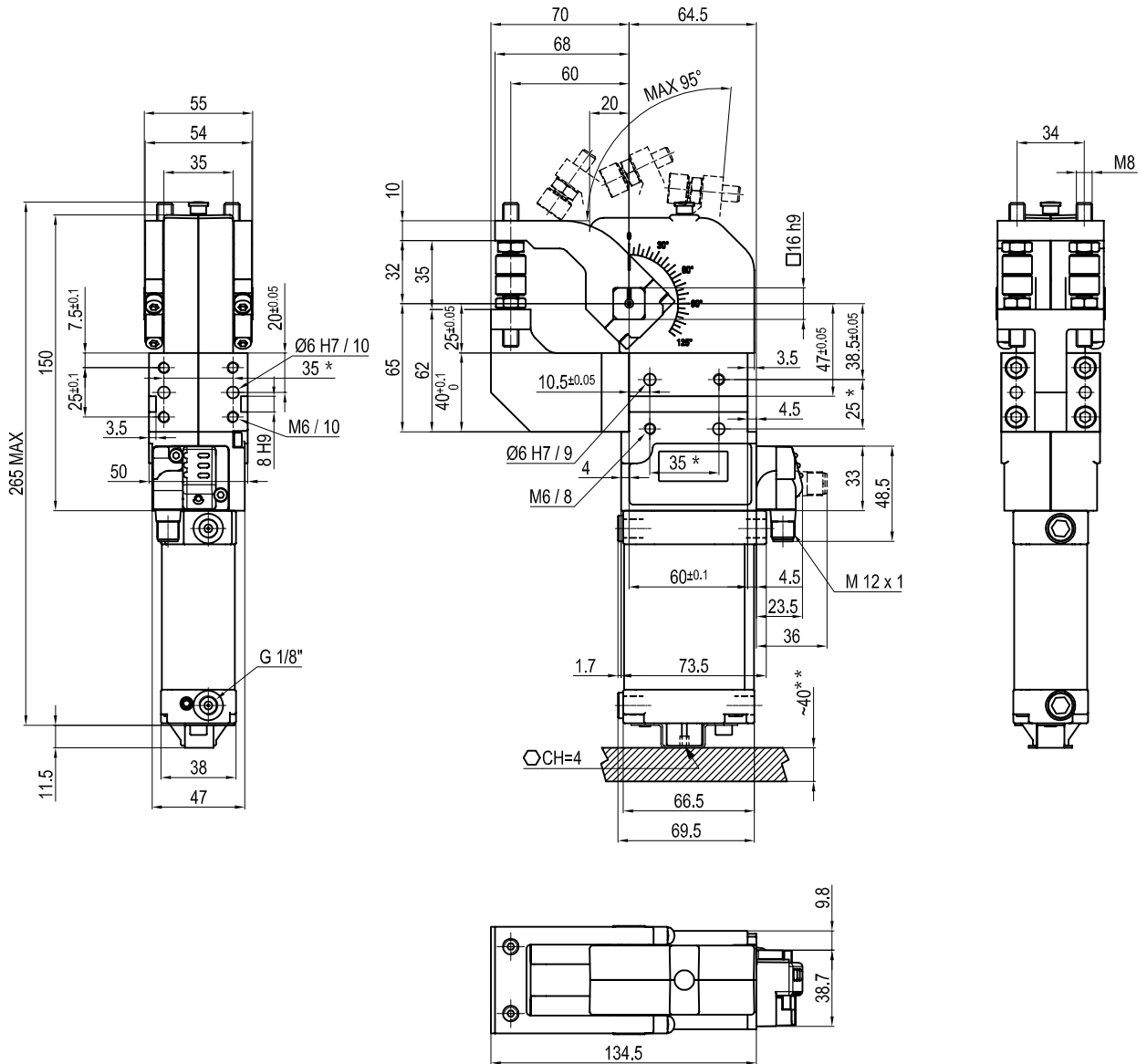

* : TOLERANCE BETWEEN DOWELS ± 0.02, TO SCREW HOLES ± 0.1

** : AREA TO ACCESS ANGLE ADJUSTMENT



UGP40OLU Pneumatic Gripper

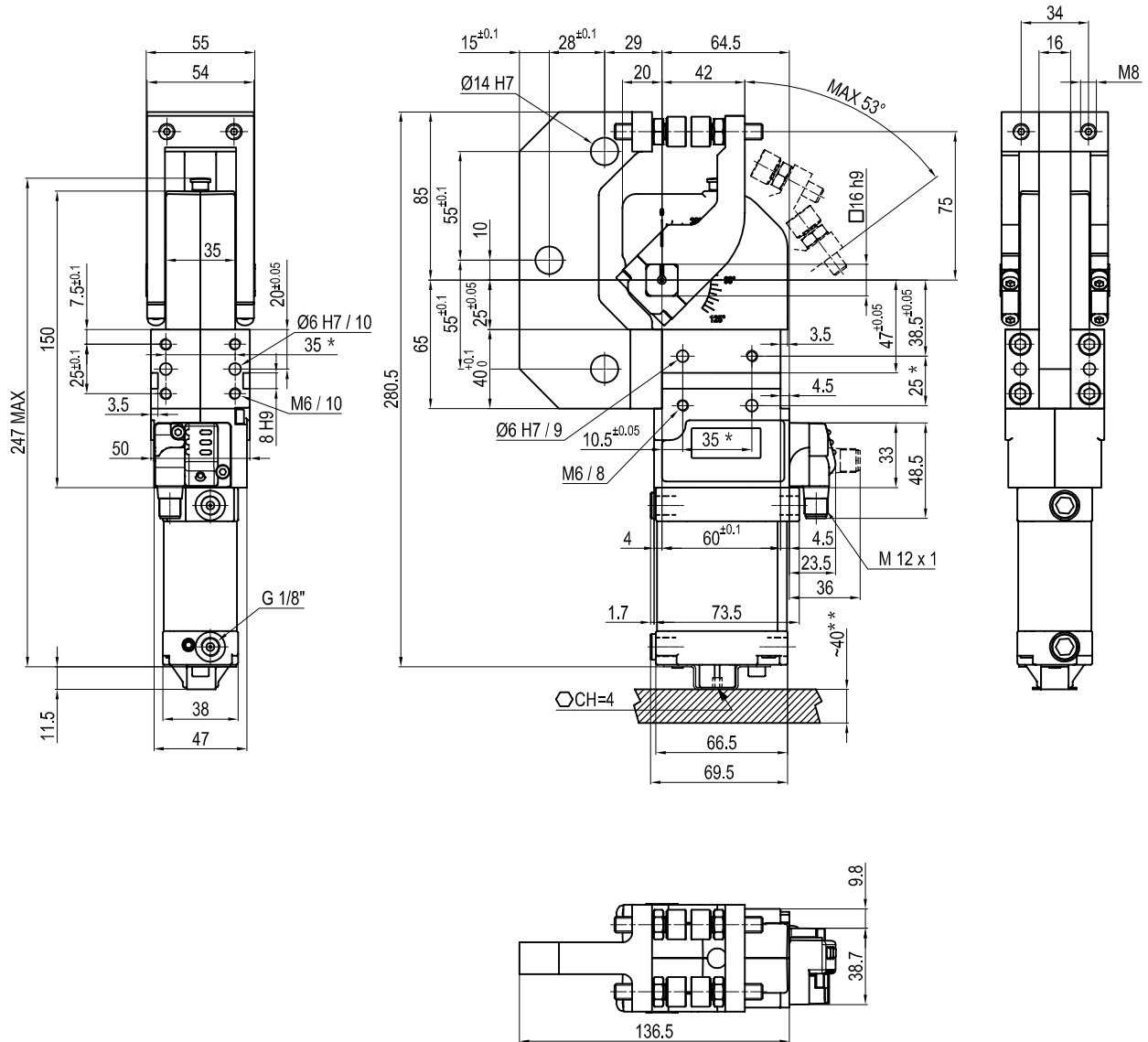

* : TOLERANCE BETWEEN DOWELS ± 0.02 , TO SCREW HOLES ± 0.1

** : AREA TO ACCESS ANGLE ADJUSTMENT