

fieldbus

G3 Fieldbus

Electronics and I/O

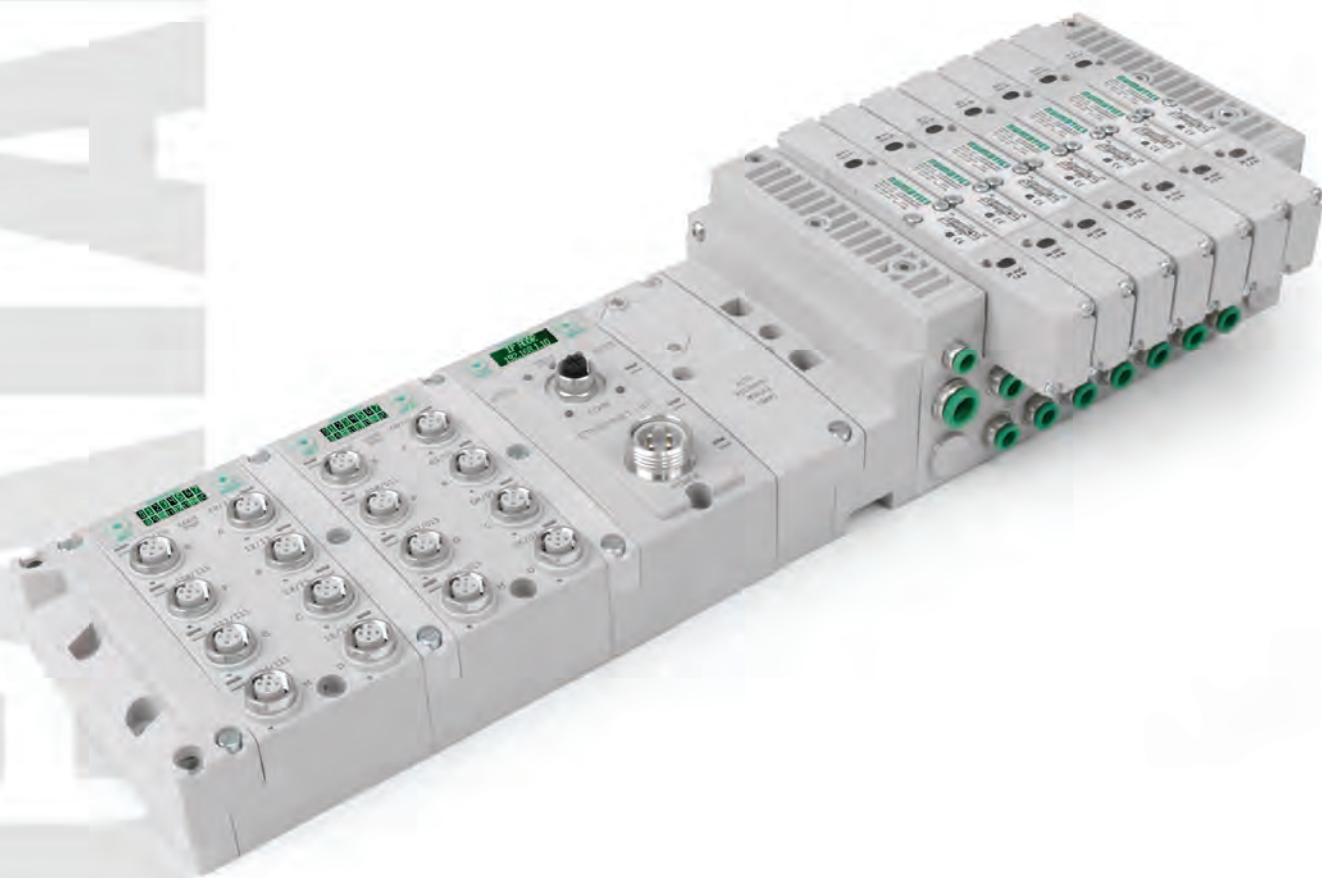

numatics®

www.numatics.com

EMERSON
Industrial Automation

NUMATICS®

Numatics, Inc. is a leading manufacturer of pneumatic products and motion control products. Our broad spectrum of standard, custom developed products and application components, have made a significant impact on pneumatic innovation as well as pneumatic and motion control technology. Our company has an extensive history of generating innovative concepts and technological breakthroughs. Many of today's standard features in pneumatic technology were industry firsts from Numatics. We continue our innovative approach to product development by developing electric motion control solutions and enhancing our embedded Fieldbus and I/O products to continually meet and solve our customer's application requirements.



Today Numatics is proud to be a part of the Industrial Automation Division of Emerson Electric Co.

Emerson (NYSE: EMR) is a global company that brings together technology and engineering to provide innovative solutions for customers in a wide range of industrial, commercial, and consumer markets.

Numatics, along with the vast resources of the Emerson organization, will assure that our proud history of innovation and service will continue to meet the needs of our global customers.

G3 Fieldbus Electronics and I/O

Section 1

Features and Benefits	2
G3 Platform Distribution Options	3-5
DeviceNet™	6
Ethernet	7
Profibus-DP®	8
PROFINET®	9
CANopen®	10
DeviceLogix™	11
I/O Modules - Digital Inputs - Terminal strip modules & valve side output module	12
I/O Modules - Digital I/O-5 Pin M12 Modules	13
I/O Modules - Analog I/O (16 bit resolution)	13
Sub-Bus Modules	14
Miscellaneous Modules	15
Miscellaneous Modules & Accessories	16
Dimensional Drawing - G3 Fieldbus Communication Assembly	17-18

Section 2

How to Configure & Order G3 Electronics	19
How to Order - G3 Assembly Kit	20
How to Order - G3 Electronics	20
How to Order Complete G3 Manifold Assemblies	21
2002 R2 & 02 Series Technical Data	22
2002 R2 & 02 Series How to Order	23
2005 Series Technical Data	24
2005 Series How to Order - Valves & Regulators	25
2012 Series Technical Data	26
2012 Series How to Order - Valves & Regulators	27
2035 Series Technical Data	28
2035 Series How to Order - Valves & Regulators	29
ISO 15407-2 Series 18 mm Technical Data	30
ISO 15407-2 Series 18 mm - How to Order	31
ISO 15407-2 Series 26 mm Technical Data	32
ISO 15407-2 Series 26 mm - How to Order	33
ISO 5599/2 Series Technical Data	34
ISO 5599/2 Series How to Order	35
G3 Power Cables and Connectors	36-38
G3 DeviceNet™/CANopen® Cables and Connectors	39
G3 Ethernet Cables and Connectors	40
G3 PROFIBUS® Cables and Connectors	41
G3 I/O Cables and Connectors	42-44
G3 Sub Bus Cables	45-46



G3 Fieldbus - Electronics Made Easy!

Innovative Graphic Display is used for easy commissioning, visual status & diagnostics.

Commissioning Capabilities

- Set network address (including IP & Subnet mask for Ethernet)
- Set baud rate
- Set auto or manual I/O sizes
- Set fault/idle output states
- Set brightness
- Set factory defaults

Visual Diagnostics

- Shorted and open load detection
- Shorted sensor/cable detection
- Low & missing power detection
- Missing module detection
- Self-test activation
- Log of network errors
- Distribution errors



Graphic Display for configuration & diagnostics



Auto Recovery Module

G3 Fieldbus Communications Electronics

Why use Numatics Fieldbus communication electronics?
Modular Reality...

- No internal wiring simplifies assembly
- SPEEDCON M12 connector technology allows for fast and efficient 1/2 turn I/O connector attachment.
- Power connector allows output power to be removed while inputs and communication are left active.
- IP65 & IP67 protection
- Up to 1200 Input / 1200 Output capability with one communication node! (Present physical I/O combinations allows 1200 I / 544 O)
- 32 valve solenoids per manifold up to 17 manifolds per communication node!
- One node supports 16 I/O modules – Analog I/O, Digital I/O (NPN & PNP) and Specialty
- Innovative clip design allows easy module removal/replacement without dismantling manifold
- Auto Recovery Module (ARM) protects configuration information during a critical failure. Allows configuration information to be saved and reloaded to replacement module automatically.



Highly Distributable



Easy, Robust Connections

Supported Protocols

- DeviceNet™
- DeviceNet™ w/Quick Connect
- Ethernet
- PROFIBUS®-DP
- CANopen®
- PROFINET®
- DeviceNet™ w/DeviceLogix™



* Numatics I/O with SPEEDCON technology

- 1/2 turn for faster I/O connections
- Backwards compatible with standard M12 cables/connectors
- Meets the same IP/NEMA standards as M12/Micro cables/connectors
- Same cost as standard M12/Micro cables/connectors
- See pages 42 & 45 for cables with SPEEDCON connector technology

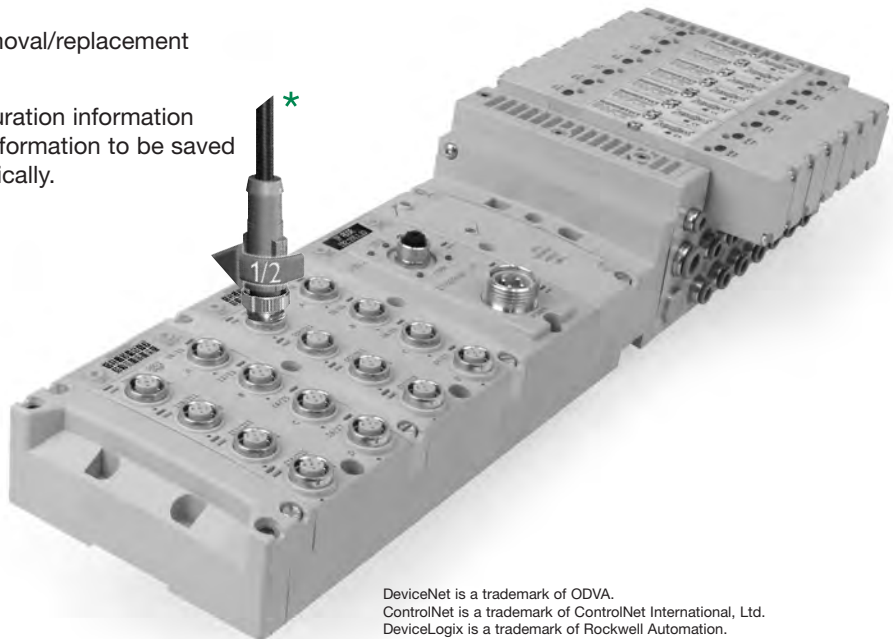

DeviceNet is a trademark of ODVA.
ControlNet is a trademark of ControlNet International, Ltd.
DeviceLogix is a trademark of Rockwell Automation.
AS-interface is a registered trademark of AS-International.
PROFIBUS and PROFINET are registered trademarks of Profibus International.
FOUNDATION Fieldbus is a trademark of Fieldbus Foundation.
InterBus-S is a trademark of Phoenix Contact.



G3 Electronics Modularity

Discrete I/O

The G3 Series product line is a completely modular system. All of the G3 electronic modules plug together, via mechanical clips, allowing easy assembly and field changes. This makes the system highly distributable. Additional flexibility is incorporated because the same modules can be used in either centralized or distributed applications.

The G3 electronics interfaces with the highly modular Numatics generation 2000 Series, ISO 5599/2 and ISO 15407-2 Series valve lines to further enhance the modularity and flexibility of the entire system.

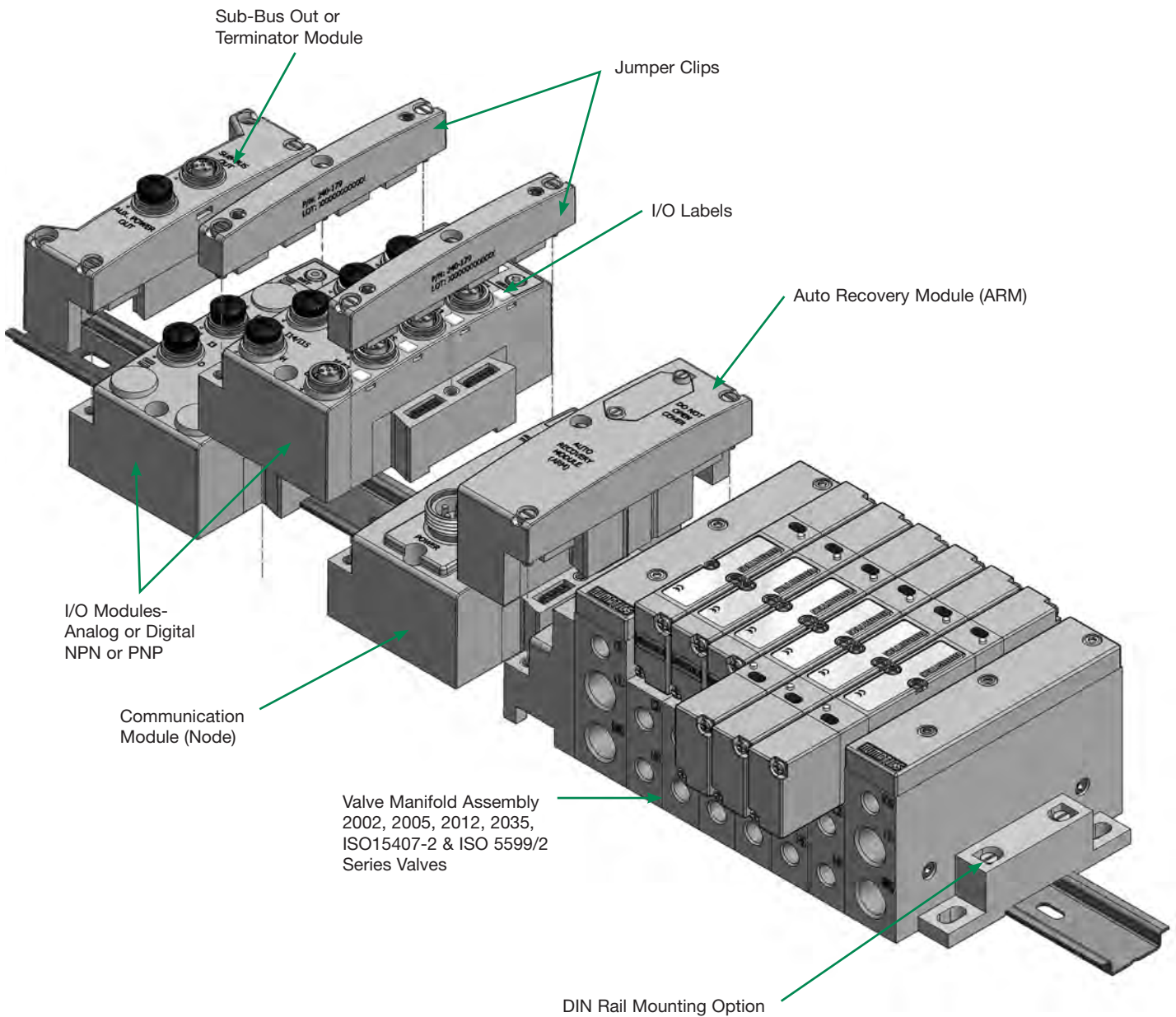



G3 Platform Distribution Options

Easy, Cost Effective Solutions for Digital I/O and Valve Automation using G3 Electronics

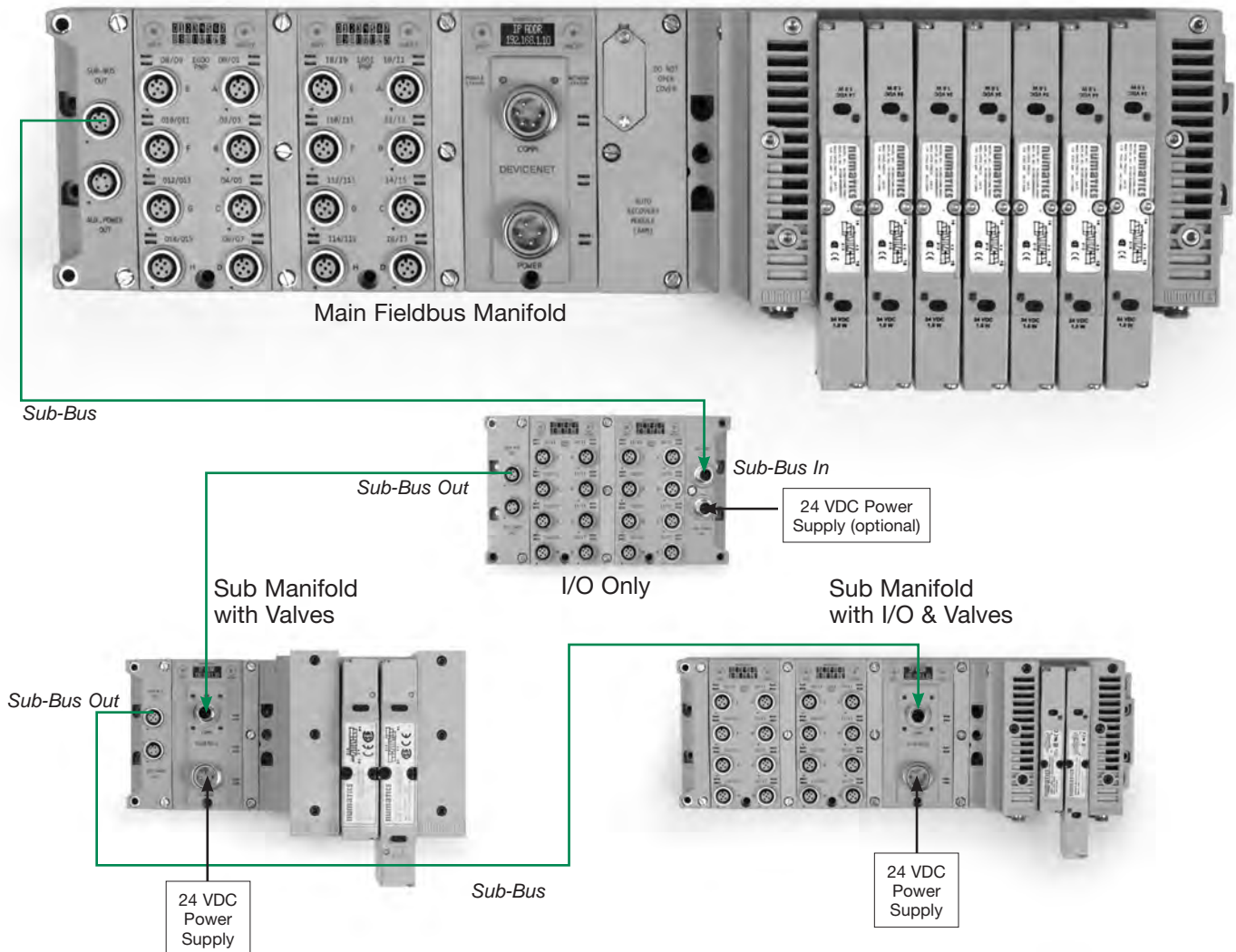

- Unique distribution system allows system efficiency by allowing the same modules to be used in either centralized or distributed applications
- Distribution options include:
 - Inputs OR Outputs
 - Inputs AND Outputs
 - Valves with Inputs AND Outputs
 - Valves with Inputs OR Outputs
 - Valves Only
- Maximum Sub-Bus length not to exceed 30 meters. Maximum Sub-Bus cable current not to exceed 4 amps or excessive cable voltage drops per segment. Auxiliary power connections available for currents above 4 amps. Consult factory for possible deviations.



G3 Platform Distribution Options

The G3 platform is flexible to the point that there are a virtually infinite number of I/O distribution options using the few basic G3 modules. The following basic rules should be followed in the configuration of your control architecture.

Valve Side

- Up to a total of 32 valve solenoids can be driven in a manifold assembly integrated into the Main Fieldbus Manifold. This can be any number of single or double solenoid valves with a total number of solenoids not to exceed 32.
- A Valve side output module is available. If a valve side output module is used, 16 outputs are allocated to the solenoids in the integral manifold and 16 are allocated to the output module in the manifold.

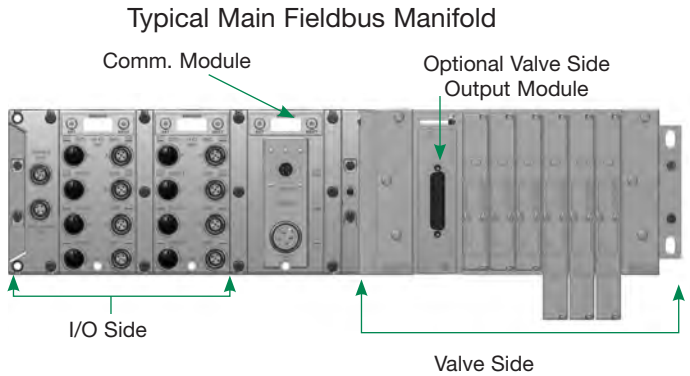

I/O Side Distribution

- A total of 16 modules can be integrated into the network and controlled by the main fieldbus communication module (Node)
- Modules include analog and digital I/O modules providing addressing capacity for up to 1200 Inputs / 1200 Outputs per node.
- Unique distribution system allows system efficiency by allowing the same modules to be used in either centralized or distributed applications
- Distribution options include Inputs only, Outputs only, I/O only, valves with Inputs, valves with Outputs and valves with I/O
- Configuration can include up to 16 of the following modules:
 - Digital I/O modules
 - Sub-Bus valve modules
 - Analog I/O modules

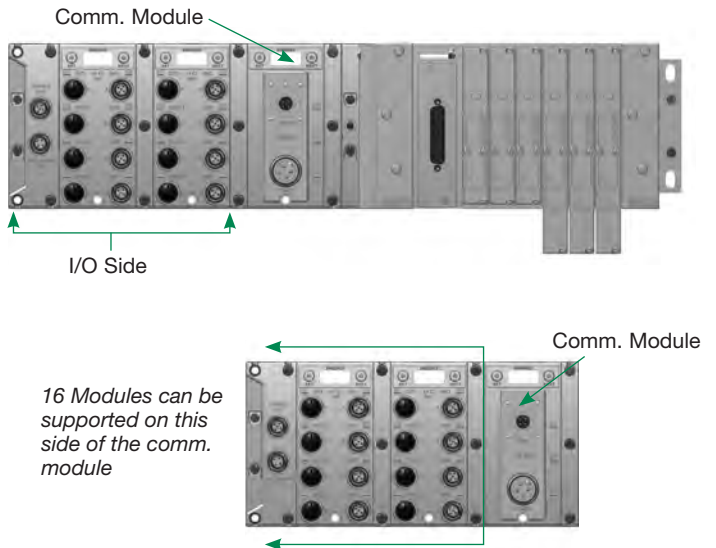



DeviceNet™

DeviceNet™ is an open bus fieldbus communication system developed by Allen-Bradley based on Controller Area Network (CAN) technology. The governing body for DeviceNet™ is the Open DeviceNet™ Vendors Association (ODVA). The ODVA controls the DeviceNet™ specification and oversees product conformance testing.

Numatics' G3 nodes for DeviceNet™ have an integrated graphic display and are capable of addressing combinations of up to 1200 Outputs and 1200 Inputs.

They have been tested and approved for conformance by the ODVA.

More information about DeviceNet™ and the ODVA can be obtained from the following WEB site:
www.odva.org



DESCRIPTION	REPLACEMENT PART NUMBER
DeviceNet™ communications module (node)	240-180

Technical Data

ELECTRICAL DATA	VOLTAGE	CURRENT
Node Power at Max. Brightness	24 VDC +/- 10%	0.070 Amps
BUS Power	11-25 VDC	0.025 Amps
Valves & Discrete I/O	24 VDC +/- 10%	8 Amps Maximum
Power Connector	Single key 4 pin 7/8" MINI type (male)	
Communication Connector	Single key 5 pin 7/8" MINI type (male)	
LED's	Module Status and Network Status	
OPERATING DATA		
Temperature Range (ambient)	-10° to 115° F (-23° to +50° C)	
Humidity	95% relative humidity, non-condensing	
Vibration / Shock	IEC 60068-2-27, IEC60068-2-6	
Moisture Protection	IP65, IP67 (with appropriate assembly and termination)	
CONFIGURATION DATA		
Graphic Display	Display used for setting Node Address, Baud Rate, Fault / Idle Actions, DeviceNet™ QuickConnect and all other system settings.	
MCM	(Manual Configuration Module) Optional module containing DIP switches for setting node address and baud rate.	
ARM	(Auto Recovery Module) Optional module that contains automatic recovery of system setting in the event of total or partial system failure.	
Maximum Valve-Solenoid Outputs	32	
Maximum Addressable I/O Points	Various combinations of 1200 outputs and 1200 inputs	
NETWORK DATA		
Supported Baud Rates	125K Baud, 250K Baud, 500K Baud, with Auto-Baud detection	
Supported Connection Type	Polled, Cyclic, Change of State (COS) and combination Message Capability	
Bus Connector	Single key 5 pin 7/8" MINI type (male)	
Diagnostics	Power, short, open load conditions and module health are monitored	
Special Features	Supports Auto-Device Replacement (ADR) and fail-safe device settings	
WEIGHT		
DeviceNet™ Communication Module	252g / 8.9 oz.	



Ethernet

Ethernet used throughout the world to network millions of PC's has now evolved into a viable industrial network. Ethernet is an open architecture high-level communication network that meets the demands of today's industrial applications requiring high-speed (10/100 Mbit/s), high-throughput and flexibility. Various application layers for this protocol including EtherNet/IP and Modbus TCP. Additionally, Ethernet technology can integrate an on-board Web server, which can make the node readily accessible to any standard Web browser for configuration, testing and even retrieval of technical documentation.

Numatics' G3 nodes for Ethernet have an integrated graphic display and are capable of addressing combinations of up to 1200 Outputs and 1200 Inputs.

The G3 Ethernet/IP nodes have been tested and approved for conformance by the ODVA.

More information about Ethernet/IP and the ODVA can be obtained from the following WEB site: www.odva.org



DESCRIPTION	REPLACEMENT PART NUMBER
Ethernet/IP communications module (node)	240-181
Modbus TCP/IP communications module (node)	240-292

Technical Data

ELECTRICAL DATA	VOLTAGE	CURRENT
Node Power at Max. Brightness	24 VDC +/- 10%	.091 Amps
Valves & Discrete I/O	24 VDC +/- 10%	8 Amps maximum
Power Connector	Single key 4 pin 7/8" MINI type (male)	
Communication Connector	D-coded 4 pin M12 type (female)	
LED's	Module Status, Network Status and Activity/Link	
OPERATING DATA		
Temperature Range (ambient)	-10° to 115° F (-23° to +50° C)	
Humidity	95% relative humidity, non-condensing	
Vibration / Shock	IEC 60068-2-27, IEC60068-2-6	
Moisture Protection	IP65, IP67 (with appropriate assembly and termination)	
CONFIGURATION DATA		
Graphic Display	Display used for setting IP Address, Subnet mask, Fault / Idle Actions, DHCP / BootP and all other system settings.	
MCM	(Manual Configuration Module) Optional module containing DIP switches for setting IP address.	
ARM	(Auto Recovery Module) Optional module that contains automatic recovery of system setting in the event of total or partial system failure	
Maximum Valve-Solenoid Outputs	32	
Maximum Addressable I/O Points	Various combinations of 1200 outputs and 1200 inputs	
NETWORK DATA		
Supported Baud Rates	10 Mbit / 100 Mbit	
Bus Connector	D-coded 5 pin M12 type (female)	
Diagnostics	Power, short, open load conditions and module health are monitored	
Special Features	Integrated web server and fail-safe device settings	
WEIGHT		
Ethernet Communication Module	255g / 9 oz.	



PROFIBUS-DP®

PROFIBUS-DP® is a vendor-independent, open fieldbus protocol designed for communication between automation control systems and distributed I/O at the device level.

Numatics' G3 nodes for PROFIBUS-DP® have an integrated graphic display and are capable of addressing combinations of up to 1200 Outputs and 1200 Inputs.

The G3 nodes for PROFIBUS-DP® have been designed and tested to conform to the PROFIBUS® standard EN50170. Certification has been done by the PROFIBUS® Interface Center (PIC) according to the guidelines determined by the PROFIBUS® Trade Organization (PTO). The certification process ensures interoperability for all PROFIBUS® devices.

More information regarding PROFIBUS® can be obtained from the following WEB site:
www.profibus.com



DESCRIPTION	REPLACEMENT PART NUMBER
PROFIBUS-DP® communications module (node)	240-239

Technical Data

ELECTRICAL DATA	VOLTAGE	CURRENT
Node Power at Max. Brightness	24 VDC +/- 10%	.094 Amps
Valves & Discrete I/O	24 VDC +/- 10%	8 Amps maximum
Power Connector	Single key 5 pin 7/8" MINI type (male)	
Communication Connector	Single reverse key (B-Coded) 5 pin M12 type (1 male and 1 female)	
LED's	Module Status and Network Status	
OPERATING DATA		
Temperature Range (ambient)	-10° to 115° F (-23° to +50° C)	
Humidity	95% relative humidity, non-condensing	
Vibration / Shock	IEC 60068-2-27, IEC60068-2-6	
Moisture Protection	IP65, IP67 (with appropriate assembly and termination)	
CONFIGURATION DATA		
Graphic Display	Display used for setting Node Address, Baud Rate, Fault / Idle Actions, and all other system settings.	
MCM	(Manual Configuration Module) Optional module containing DIP switches for setting node address and baud rate.	
ARM	(Auto Recovery Module) Optional module that contains automatic recovery of system setting in the event of total or partial system failure	
Maximum Valve-Solenoid Outputs	32	
Maximum Addressable I/O Points	Various combinations of 1200 outputs and 1200 inputs	
NETWORK DATA		
Supported Baud Rates	Auto-Baud from 9.6k to 12M Baud	
Bus Connector	Single reverse key (B-Coded) 5 pin M12 type (1 male and 1 female)	
Diagnostics	Power, short, open load conditions and module health are monitored	
Special Features	Supports Class 2 PROFIBUS-DP® master with auto-configuration and fail-safe device settings	
WEIGHT		
PROFIBUS-DP® Communication Module	227g / 8 oz.	



PROFINET®

PROFINET® is the innovative open standard for Industrial Ethernet, development by Siemens and the Profibus® User Organization (PNO). PROFINET® complies to IEC 61158 and IEC 61784 standards. PROFINET® products are certified by the PNO user organization, guaranteeing worldwide compatibility.

Numatics' G3 nodes for PROFINET IO (PROFINET RT) have an integrated graphic display and are capable of addressing combinations of up to 1200 Outputs and 1200 Inputs.

PROFINET® is based on Ethernet and uses TCP/IP and IT standards and complements them with specific protocols and mechanisms to achieve Real Time performance.

More information regarding PROFINET® can be obtained from the following WEB site:
www.profibus.com



DESCRIPTION	REPLACEMENT PART NUMBER
PROFINET® communications module (node)	240-240

Technical Data

ELECTRICAL DATA	VOLTAGE	CURRENT
Node Power at Max. Brightness	24 VDC +/- 10%	
Valves & Discrete I/O	24 VDC +/- 10%	8 Amps maximum
Power Connector	Single key 5 pin 7/8" MINI type (male)	
Communication Connector	Two D-coded 4 pin M12 type (female)	
LED's	Module Status, Network Status and Activity/Link	
OPERATING DATA		
Temperature Range (ambient)	-10° to 115° F (-23° to +50° C)	
Humidity	95% relative humidity, non-condensing	
Vibration / Shock	IEC 60068-2-27, IEC60068-2-6	
Moisture Protection	IP65, IP67 (with appropriate assembly and termination)	
CONFIGURATION DATA		
Graphic Display	Display used for setting IP Address, Subnet Mask, Fault / Idle Actions, and all other system settings.	
MCM	(Manual Configuration Module) Optional module containing DIP switches for setting node address.	
ARM	(Auto Recovery Module) Optional module that contains automatic recovery of system setting in the event of total or partial system failure.	
Maximum Valve-Solenoid Outputs	32	
Maximum Addressable I/O Points	Various combinations of 1200 outputs and 1200 inputs	
NETWORK DATA		
Supported Baud Rates	10 Mbit / 100 Mbit	
Bus Connector	Two D-coded 4 pin M12 type (2-Female)	
Diagnostics	Power, short, open load conditions and module health and configuration are monitored	
Special Features	Integrated web server, Integrated 2 port switch and fail-safe device settings	
WEIGHT		
PROFINET® Communication Module	227g / 8 oz.	



CANopen®

CANopen® is an open protocol based on Controller Area Network (CAN). It was designed for motion oriented machine control networks but has migrated to various industrial applications. CAN in Automation (CIA) is the international users' and manufacturers' organization that develops and supports CAN-based protocols. Numatics' G3 nodes for CANopen® have an integrated graphic display and are capable of addressing combinations of up to 1200 Outputs and 1200 Inputs.

More information regarding this organization can be found at: www.can-cia.org



DESCRIPTION	REPLACEMENT PART NUMBER
CANopen® communications module (node)	240-291

Technical Data

ELECTRICAL DATA	VOLTAGE	CURRENT
Node Power at Max. Brightness	24 VDC +/- 10%	0.070 Amps
BUS Power	11-25 VDC	0.025 Amps
Valves & Discrete I/O	24 VDC +/- 10%	8 Amps maximum
Power Connector	Single key 4 pin 7/8" MINI type (male)	
Communication Connector	Single key 5 pin 7/8" MINI type (male)	
LED's	Module Status and Network Status	
OPERATING DATA		
Temperature Range (ambient)	-10° to 115° F (-23° to +50° C)	
Humidity	95% relative humidity, non-condensing	
Vibration / Shock	IEC 60068-2-27, IEC60068-2-6	
Moisture Protection	IP65, IP67 (with appropriate assembly and termination)	
CONFIGURATION DATA		
Graphic Display	Display used for setting Node Address, Baud Rate, Fault / Idle Actions, and all other system settings.	
MCM	(Manual Configuration Module) Optional module containing DIP switches for setting node address and baud rate.	
ARM	(Auto Recovery Module) Optional module that contains automatic recovery of system setting in the event of total or partial system failure.	
Maximum Valve-Solenoid Outputs	32	
Maximum Addressable I/O Points	Various combinations of 1200 outputs and 1200 inputs	
NETWORK DATA		
Supported Baud Rates	125K Baud, 250K Baud, 500K Baud, 1M Baud	
Bus Connector	Single key 5 pin 7/8" MINI type (male)	
Diagnostics	Power, short, open load conditions and module health are monitored and fail-safe device settings	
WEIGHT		
CANopen® Communication Module	252g / 8.9 oz.	



DeviceLogix™

DeviceLogix™ is a Rockwell Automation technology that allows a DeviceNet™ node to be programmed to execute a sequence independently from the control for the main PLC/IPC. A DeviceLogix™ enabled DeviceNet™ node can be used in conjunction with a standard DeviceNet™ network, providing simple distributed control functionality. Additionally it can also be used in a standalone application, without a network connection or PLC/IPC, to sequence pneumatic valves and control I/O. Numatics has integrated this licensed technology into its DeviceNet™ compatible valve manifold series, which combine the functionality of a modular pneumatic valve system with integrated I/O.



Programming of the DeviceLogix™ enabled node is done using the industry standard DeviceNet™ commissioning software tool RSNetWorx™ for DeviceNet™ from Rockwell Automation. The programming software features an easily understandable graphics environment where the users can simply “drag and drop” logic function blocks (i.e. AND, NAND, OR, NOR, XOR, XNOR, RS LATCHES, COUNTERS and TIMERS) onto a page and interconnect them to develop the required sequence, or ladder logic programming can be used to develop a sequence. The programmed sequence is downloaded to the node via standard DeviceNet™ communication connection, thus multiple nodes can be programmed on the same network.

DESCRIPTION	REPLACEMENT PART NUMBER
DeviceLogix™ communications module (node)	240-293

Technical Data

ELECTRICAL DATA	VOLTAGE	CURRENT
Node Power at Max. Brightness	24 VDC +/- 10%	0.070 Amps
BUS Power	11-25 VDC	0.025 Amps
Valves & Discrete I/O	24 VDC +/- 10%	8 Amps Maximum
Power Connector	Single key 4 pin 7/8" MINI type (male)	
Communication Connector	Single key 5 pin 7/8" MINI type (male)	
LED's	Module Status and Network Status	
OPERATING DATA		
Temperature Range (ambient)	-10° to 115° F (-23° to +50° C)	
Humidity	95% relative humidity, non-condensing	
Vibration / Shock	IEC 60068-2-27, IEC60068-2-6	
Moisture Protection	IP65, IP67 (with appropriate assembly and termination)	
CONFIGURATION DATA		
Communication Module	Display used for setting Node Address, Baud Rate, Fault / Idle Actions, and all other system settings.	
MCM	(Manual Configuration Module) Optional module containing DIP switches for setting node address and baud rate.	
ARM	(Auto Recovery Module) Optional module that contains automatic recovery of system setting in the event of total or partial system failure including embedded DeviceLogix™ logic instructions.	
Maximum Valve-Solenoid Outputs	32	
NETWORK DATA		
Supported Baud Rates	125K Baud, 250K Baud, 500K Baud, with Auto-Baud detection	
Supported Connection Type	Polled, Cyclic, Change of State (COS) and combination Message Capability	
Bus Connector	Single key 5 pin 7/8" MINI type (male)	
Diagnostics	Power, short, open load conditions and module health are monitored and fail-safe device settings	
Special Features	Supports function block diagram and ladder logic programming	
WEIGHT		
DeviceLogix™ Communication Module	252g / 8.9 oz.	



I/O Modules

Digital Inputs -Terminal Strip Modules

DESCRIPTION	PART NUMBER
16 PNP Inputs	240-203
16 NPN Inputs	240-204

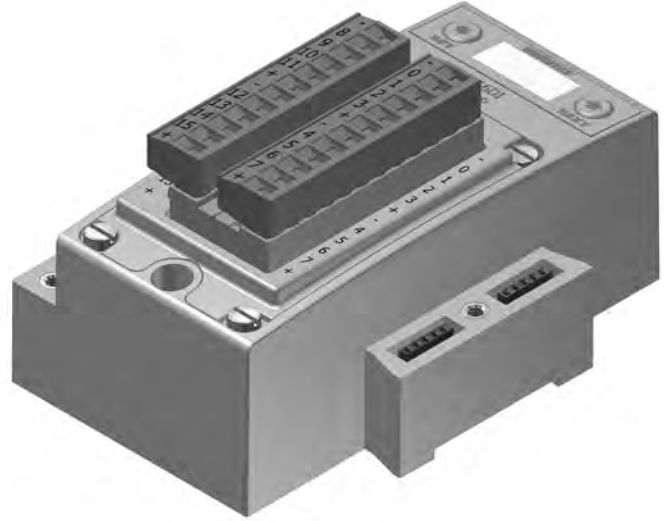

Technical Data

OPERATING DATA	
Temperature Range (ambient)	-10° to 115° F (-23° to +50° C)
Humidity	95% relative humidity, non-condensing
Vibration / Shock	IEC 60068-2-27, IEC60068-2-6
Wire Range	12 to 24 AWG
Strip Length	7 mm
Tightening Torque	0.5 Nm
Moisture Protection	IP20
SPARE PARTS	
Replacement Terminal Strip (I/O 0-7)	140-1073
Replacement Terminal Strip (I/O 8-15)	140-1074
Keying Element for terminal strip	140-1076
Keying Element for Module	140-1077
WEIGHT	
Input Module	292g / 10.3 oz.

Output Module -Valve Side-Single 25 Pin Sub D

DESCRIPTION	PART NUMBER
16 NPN Outputs	239-1713

Technical Data

OPERATING DATA	
Temperature Range (ambient)	-10° to 115° F (-23° to +50° C)
Humidity	95% relative humidity, non-condensing
Vibration / Shock	IEC 60068-2-27, IEC60068-2-6
Moisture Protection	IP20
SPARE PARTS	
Cover Gasket	113-532
Interface Gasket	113-531
WEIGHT	
Valve side output module	590g / 21 oz.





I/O Modules

Digital I/O 5-pin M12 Modules

DESCRIPTION	PART NUMBER
Inputs	
8 PNP Inputs	240-206
8 NPN Inputs	240-210
16 PNP Inputs	240-205
16 NPN Inputs	240-209
Outputs	
8 PNP Outputs	240-208
8 PNP High Current Outputs (Fig. A Only)	240-300
16 PNP Outputs	240-207
Inputs and Outputs	
8 PNP Inputs and 8 PNP Outputs	240-211



Figure A

Analog I/O with settable high and low alarms 5-pin M12 Modules

DESCRIPTION	SIGNAL TYPE	PART NUMBER
Inputs		
4 Analog Inputs	0-10 VDC	240-212
4 Analog Inputs	4-20 mA	240-214
Inputs and Outputs		
2 Analog Inputs & 2 Analog Outputs	0-10 VDC	240-213
2 Analog Inputs & 2 Analog Outputs	4-20 mA	240-215



Technical Data

OPERATING DATA	
Temperature Range	-10° to 115° F (-23° to +50° C)
Humidity	95% relative humidity, non-condensing
Vibration / Shock	IEC 60068-2-27, IEC60068-2-6
Moisture Protection	IP65, IP67 (with appropriate assembly and termination)
Connector	Female 5-pin M12 SPEEDCON
Resolution	16 bit
WEIGHT	
I/O Module-Analog	244g / 8.6 oz
I/O Module-Digital	274g / 9.7 oz

Dust Cover - M12 Male
230-647





Sub-Bus Modules

Sub-Bus Valve Module

Provides Sub-Bus In and Aux. Power In connections to a distributed valve manifold

DESCRIPTION	PART NUMBER	WEIGHT
Sub-Bus Valve Module	240-241	235g / 8.3 oz



Sub-Bus Out Module

Provides Sub-Bus Out and Aux. Power Out connections for I/O distribution

DESCRIPTION	PART NUMBER	WEIGHT
Sub-Bus Out Module with DIN Rail Clips	240-244	141g / 5.0 oz
Sub-Bus Out Module	240-183	130g / 4.6 oz



Dust Cover - M12 Male
230-647



Sub-Bus In Module

Provides Sub-Bus In and Aux. Power In connections for I/O distribution

DESCRIPTION	PART NUMBER	WEIGHT
Sub-Bus In Module with DIN Rail Clips	240-246	141g / 5.0 oz
Sub-Bus In Module	240-185	130g / 4.6 oz

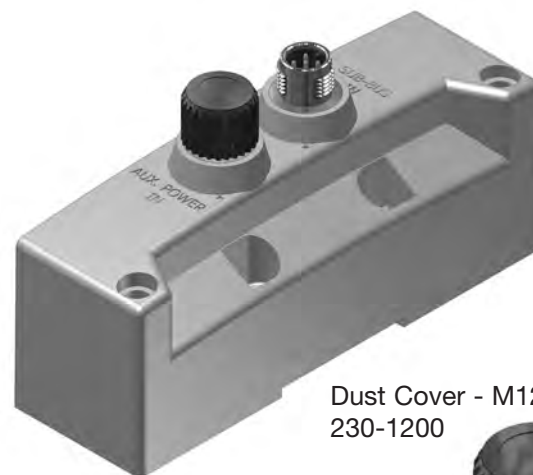

Dust Cover - M12 Female
230-1200





Miscellaneous Modules

Auto Recovery Module (ARM)

Protects configuration information during a critical failure. Allows configuration information to be saved and reloaded to replacement module automatically.

DESCRIPTION	PART NUMBER	WEIGHT
ARM Module	240-182	127g / 4.5 oz



Manual Configuration Module (MCM)

An optional module used to manually configure user parameters (e.g. node address)

DESCRIPTION	PART NUMBER	WEIGHT
MCM Module	240-186	127g / 4.5 oz



Terminator Module

Provides termination for the sub-bus. Must be installed after the last I/O module or after the communication module if there are no I/O modules installed.

DESCRIPTION	PART NUMBER	WEIGHT
Terminator Module w/ DIN Rail Clips	240-245	102g / 3.6 oz
Terminator Module	240-184	91g / 3.2 oz

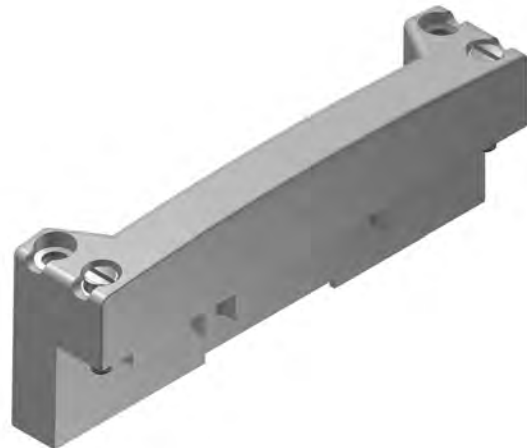



Miscellaneous Modules

Jumper Clip

Provides electrical connections between modules

DESCRIPTION	PART NUMBER	WEIGHT
Jumper Clip	240-179	45g / 1.6 oz



Valve Driver Module

Provides connections between the communication module or Sub-Bus valve module and the valve manifold

DESCRIPTION	PART NUMBER	WEIGHT
Valve Driver Module w/ DIN Rail Clips	219-858	147g / 5.2 oz
Valve Driver Module	219-828	136g / 4.8 oz

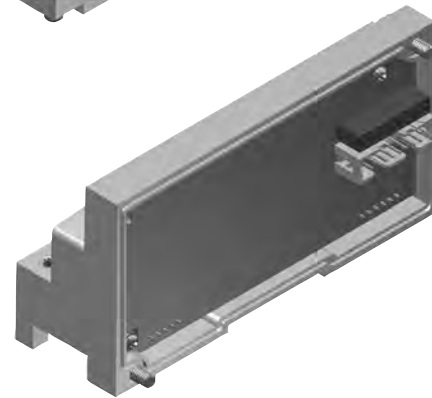

Right Hand Mounting Cover

Used when a communication module is used without local valves installed

DESCRIPTION	PART NUMBER	WEIGHT
Right Hand Mounting Cover w/ DIN Rail Clips	240-290	82g / 2.9 oz.
Right Hand Mounting Cover	240-255	71g / 2.5 oz.

* Not for use in combination with ARM Module

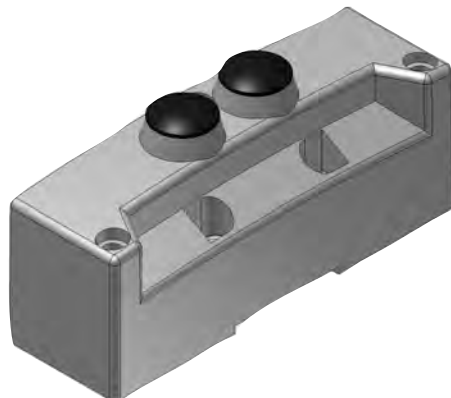

Accessories

For use with Murrplastik© Type 20 Software

Labels - 122-1251

TECHNICAL DATA	
Material	Polycarbonate (PC)
Color	White
Temperature Range	40° - 140° C
Label Dimensions	0.19" x 0.39"
Label - Printable Area	0.19" x 0.39"

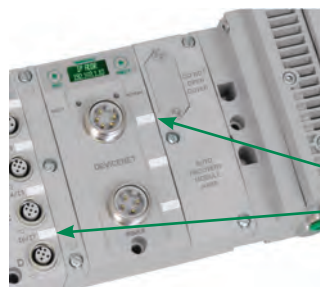



Dimensional Drawing - G3 Fieldbus Manifold Assembly

2005 Series Valve Manifold Assembly with G3 Electronics and Sub-Bus Output

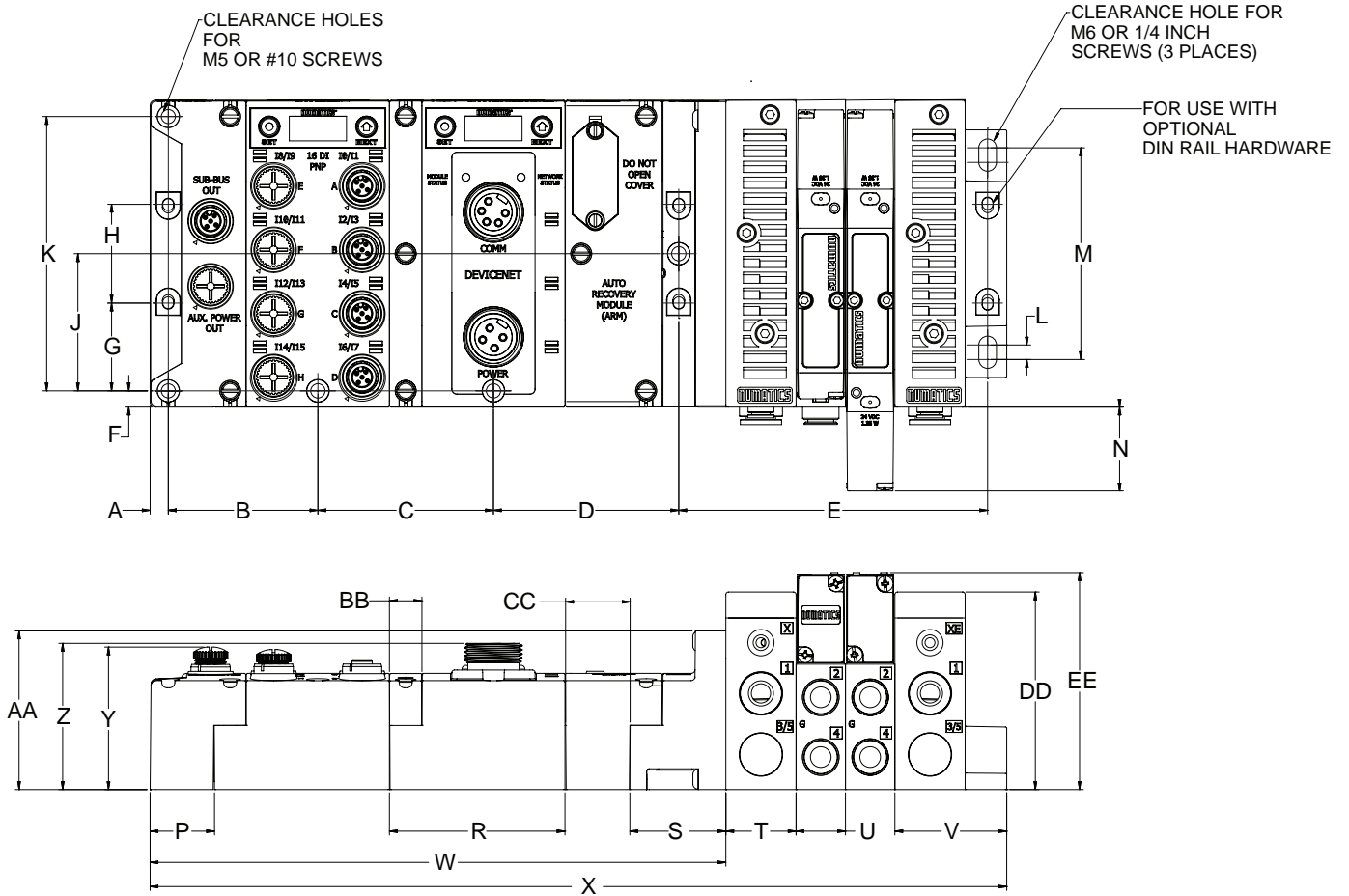

Dimensions in inches (mm)

A	B	C	D	E	F	G	H	J	K	L	M	N	P
0.28	2.26	2.66	2.81	4.68	0.25	1.33	1.50	2.08	4.15	0.22	3.20	1.27	0.97
(7.00)	(57.50)	(67.50)	(71.25)	(118.75)	(6.25)	(33.75)	(38.00)	(52.75)	(105.50)	(5.60)	(81.40)	(32.30)	(24.75)

R	S	T	U	V	W	X	Y	Z	AA	BB	CC	DD	EE
2.66	1.45	1.06	0.75	1.69	8.71	12.97	2.13	2.21	2.40	0.49	0.98	2.99	3.29
(67.50)	(36.90)	(27.00)	(19.00)	(43.00)	(221.35)	(329.35)	(54.00)	(56.25)	(61.00)	(12.50)	(24.80)	(76.00)	(83.50)



Dimensional Drawing - G3 Fieldbus I/O Assembly

I/O Assembly with G3 Electronics and Sub-Bus Input

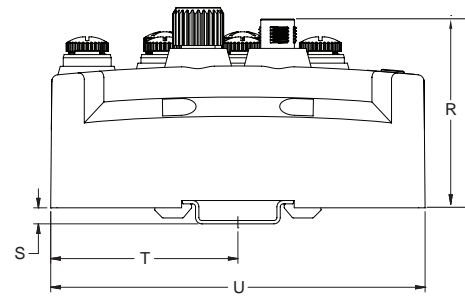
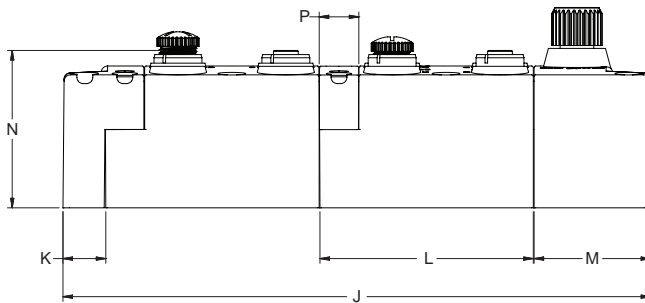
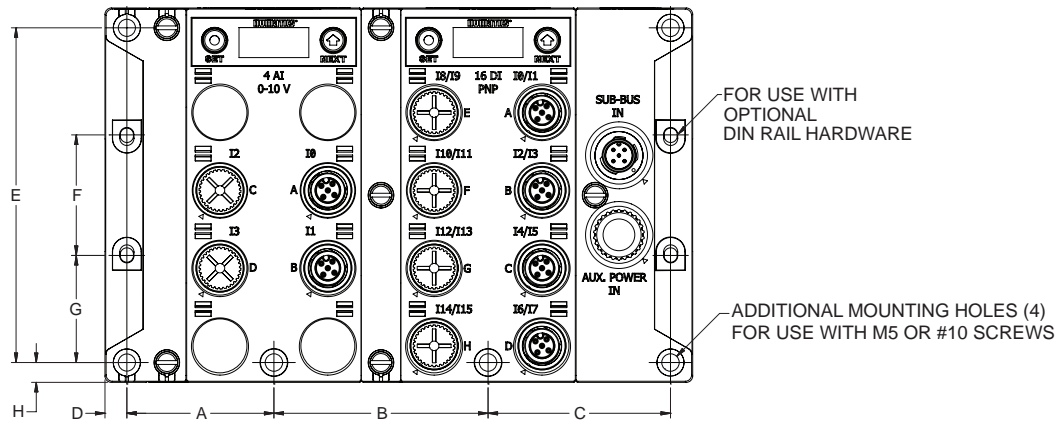

VIEW SHOWN WITH OPTIONAL DIN RAIL HARDWARE AND 35mm DIN RAIL

Dimensions in inches (mm)

A	B	C	D	E	F	G	H	J	K	L	M	N	P	R	S	T	U
1.82	2.66	2.26	0.27	4.15	1.50	1.33	0.25	7.29	0.53	2.65	1.45	2.13	0.49	2.46	0.20	2.32	4.65
(46.35)	(67.50)	(57.50)	(6.90)	(105.50)	(38.00)	(33.75)	(6.25)	(185.25)	(13.50)	(67.25)	(36.75)	(54.00)	(12.50)	(62.50)	(5.05)	(59.00)	(118.00)

G3 Fieldbus Electronics and I/O

Section 2 - How to Configure & Order G3 Electronics

How to Order - G3 Assembly Kit	20
How to Order - G3 Electronics	20
How to Order Complete G3 Manifold Assemblies	21
2002 R2 & 02 Series Technical Data	22
2002 R2 & 02 Series How to Order	23
2005 Series Technical Data	24
2005 Series How to Order - Valves & Regulators	25
2012 Series Technical Data	26
2012 Series How to Order - Valves & Regulators	27
2035 Series Technical Data	28
2035 Series How to Order - Valves & Regulators	29
ISO 15407-2 Series 18 mm Technical Data	30
ISO 15407-2 Series 18 mm - How to Order	31
ISO 15407-2 Series 26 mm Technical Data	32
ISO 15407-2 Series 26 mm - How to Order	33
ISO 5599/2 Series Technical Data	34
ISO 5599/2 Series How to Order	35
G3 Power Cables and Connectors	36-38
G3 DeviceNet™/CANopen® Cables and Connectors	39
G3 Ethernet Cables and Connectors	40
G3 PROFIBUS® Cables and Connectors	41
G3 I/O Cables and Connectors	42-44
G3 Sub Bus Cables	45-46



G3 Electronics

How To Order - G3 Assembly Kit

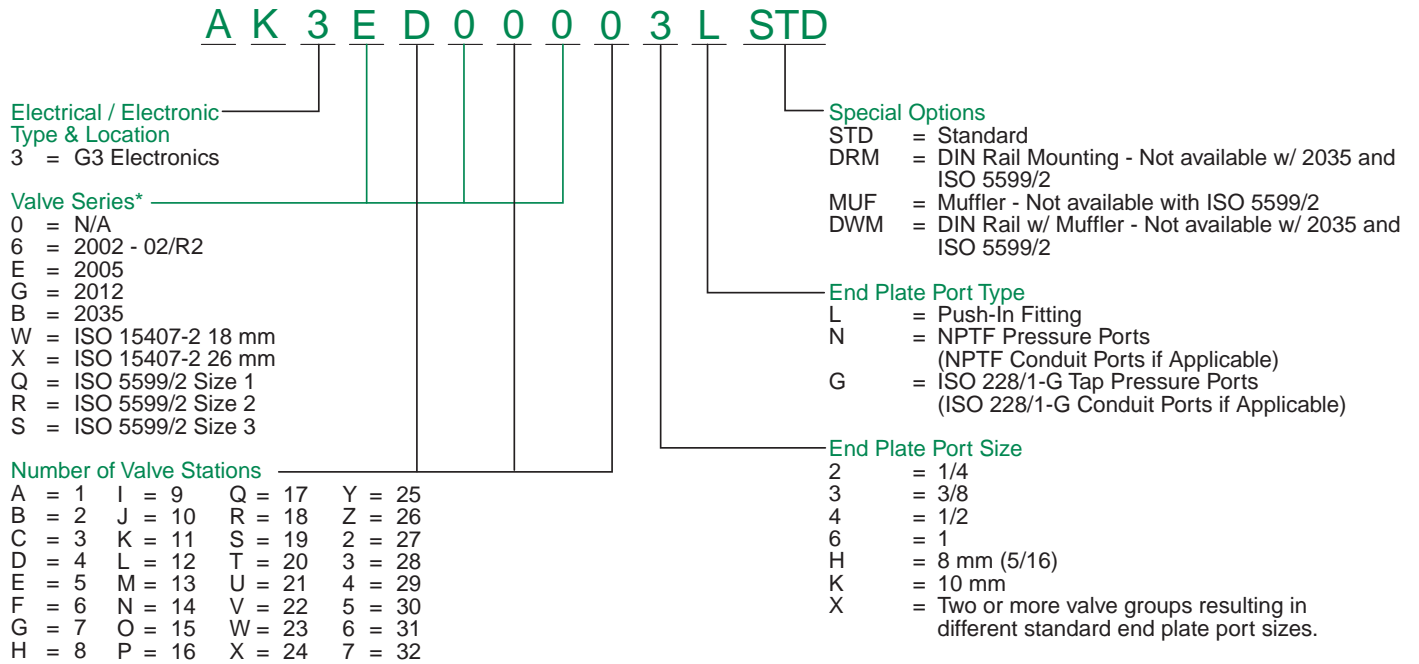

*For manifold assembly with multiple valve series - Consult Factory

How To Order - G3 Electronics

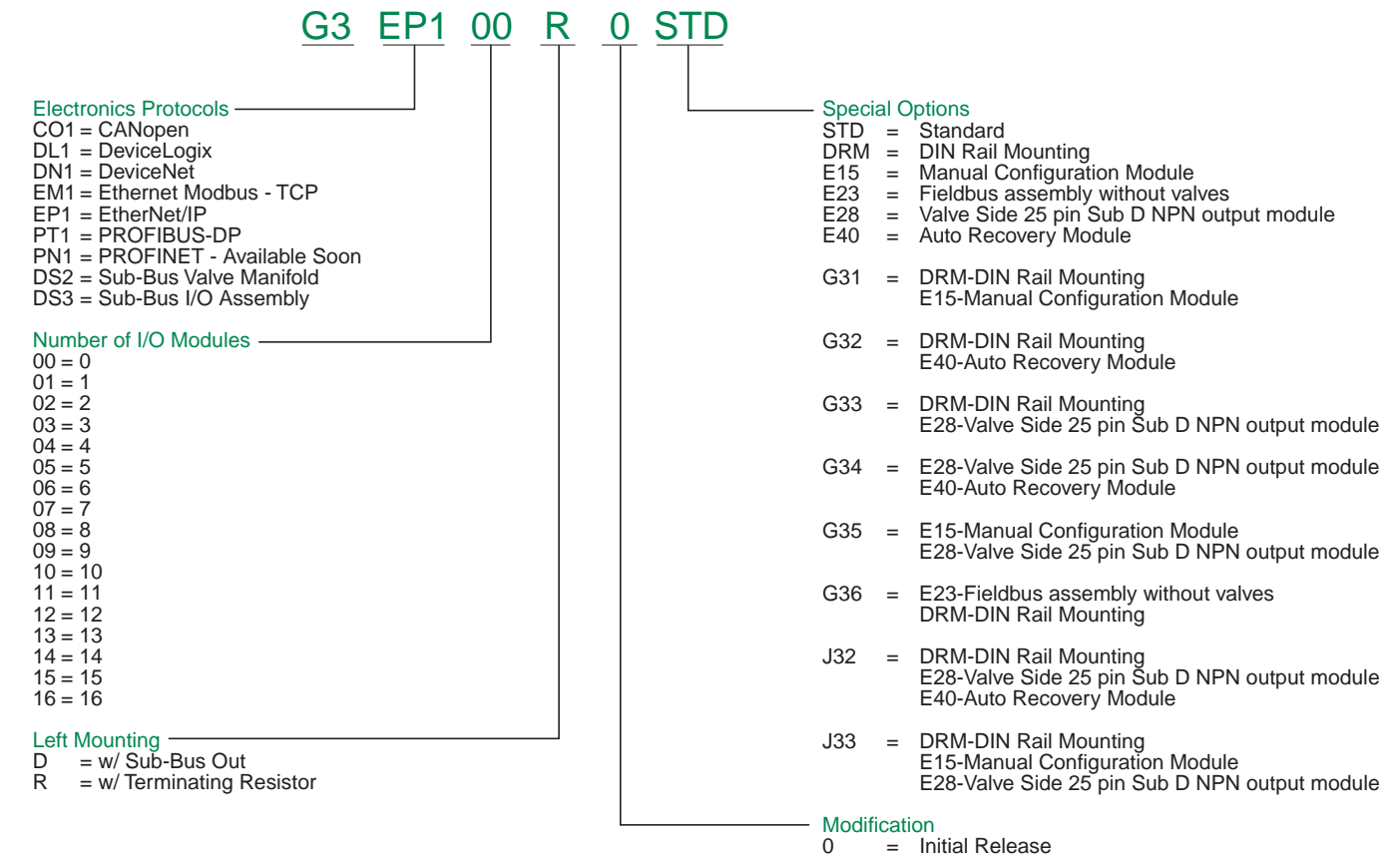



Ordering Valve Manifold Assemblies with G3 Electronics & Discrete I/O

For valve series 2002, 2005, 2012, 2035, ISO 15407-2 & ISO 5599/2 (2005 shown)

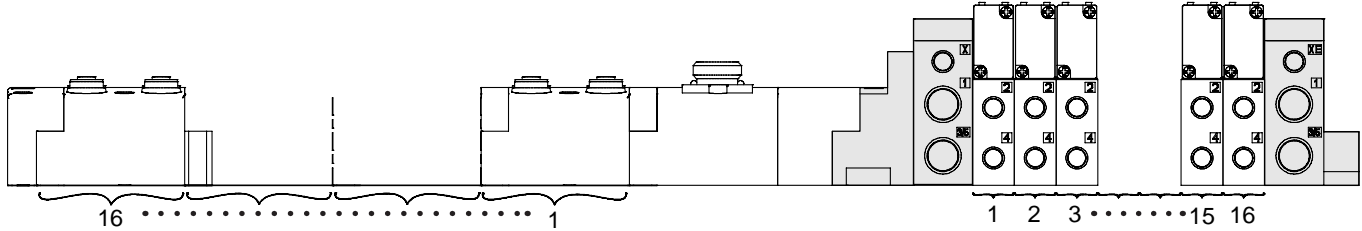

Shaded components are described by the assembly kit (AK) model number (see page 20). The communication module and number of I/O modules are described by the Electronic Interface (G3) model number designation (see page 20).

Each valve station is listed in sequential order from left to right when facing the port side of the manifold as shown.

Each discrete I/O module is listed in sequential order from RIGHT to LEFT starting from the communication module as shown.

NOTE:

1. A total of 32 solenoid outputs are available. Either 32 single solenoid valves or 16 double solenoid valves or any combination of singles and doubles not to exceed 32 outputs can be specified.
2. For manifold assemblies that exceed 16 solenoids, the assembly **MUST** be configured so that an even number of solenoids are utilized prior to the station using the ribbon cable feature. The 16th and the 17th solenoids cannot be on the same valve.

Example Order - 2005 Shown

Assy Kit	AK3EP00003LMUF
Station 1	052BB4Z2ML00061
Station 2	052BB4Z2ML00061
Station 3	052BB4Z2ML00061
Station 4	052BB4Z2ML00061
Station 5	052BB4Z2ML00061
Station 6	052BB4Z2ML00061
Station 7	052BB4Z2ML00061
Station 8	052BB4Z2ML00061
Station 9	052BB4R2ML00061
Station 10	052BB4Z2ML00061
Station 11	052BB4Z2ML00061
Station 12	052BB4Z2ML00061
Station 13	052BB4Z2ML00061
Station 14	052BB4Z2ML00061
Station 15	052BB4Z2ML00061
Station 16	052BB4Z2ML00061
Electronics	G3DN116R0E40
Station 1	240-205
Station 2	240-205
⋮	
Station 15	240-205
Station 16	240-205

Ordering G3 Electronics Assemblies with I/O Only

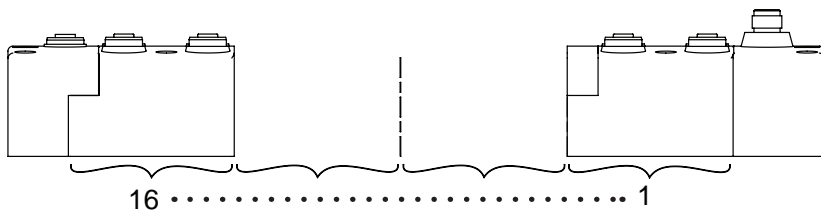

1. Refer to the selection table on page 20 to specify the control electronics and I/O configuration.
2. Each discrete I/O module is listed in sequential order from RIGHT to LEFT as shown.
3. A maximum of 16 I/O modules are supported by a single communication node. Analog I/O & digital I/O (NPN & PNP)

Example Order - I/O assembly with Sub-Bus in and Sub-Bus out modules

Electronics	G3DS316D0STD
Station 1	240-205
Station 2	240-205
⋮	
Station 15	240-205
Station 16	240-205



2002 R2 & O2 Series

2002-R2 & O2 Series Functions

single solenoid air pilot
2 position 4-way

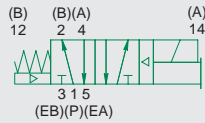

double solenoid air pilot
2 position 4-way

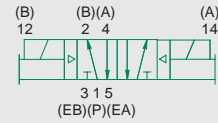

double solenoid air pilot
3 position 4-way
open center

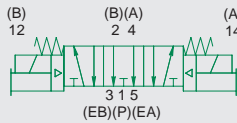

double solenoid air pilot
3 position 4-way
closed center

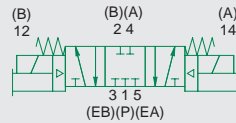

2002-R2 Series Only Functions

double solenoid
air pilot
dual 3-way
"12(B)" & "14(A)" NO

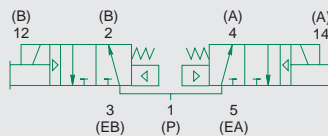

double solenoid
air pilot
dual 3-way
"12(B)" & "14(A)" NC

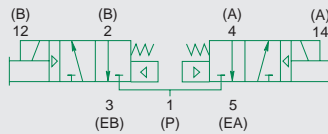

double solenoid
air pilot
2 position dual 3-way
"12(B)" NO, "14(A)" NC

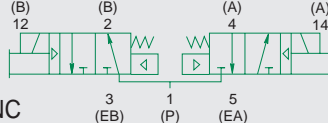

5 Ported, 2 and 3 position, 4-way and dual 3-way,
Packed Spool

Cv: 0.25 (4-way) 0.25 (Dual 3-way) R2 Series

Spool and Sleeve

Cv: 0.20 (4-way) O2 Series

- Solenoid air pilot actuated
- Low wattage coil
- Elimination of internal wiring
- Buna-N seals provide leakproof sealing
- Pusher piston – high spool shifting force
- Adjustable port sizes utilizing interchangeable cartridge fittings



Technical Data

VALVE DATA	ENGLISH		METRIC	
	R2 SERIES	O2 SERIES	R2 SERIES	O2 SERIES
Cv	0.25	0.2	0.25	0.2
Flow Capacity	11.5 SCFM @ 80 PSIG upstream pressure to atmosphere	9.2 SCFM @ 80 PSIG upstream pressure to atmosphere	246 NI/m @ 6 bar upstream pressure to 5 bar downstream	197 NI/m @ 6 bar upstream pressure to 5 bar downstream
Operating Pressure Range	28" Hg to 100 PSIG	28" Hg to 150 PSIG	Vacuum to 7 bar	Vacuum to 10 bar
Pilot Pressure Range	35 to 100 PSIG	35 to 100 PSIG	2.5 to 7 bar	2.5 to 7 bar
Temperature Range (Ambient)	-10°F to +115°F	-10°F to +115°F	-23°C to +50°C	-23°C to +50°C

Operating Data

ALL SOLENOIDS ARE CONTINUOUS DUTY RATED 24 VDC

Power (Watts)	0.5
Holding Current (Amps)	0.02

RESPONSE TIME IN SECONDS	ENERGIZE		DE-ENERGIZE	
	R2 SERIES	O2 SERIES	R2 SERIES	O2 SERIES
2-Position, Single, Spring Return	0.017	0.014	0.013	0.20
2-Position, Double, Detented	0.010	0.010	N/A	N/A
3-Position, Spring Centered	0.009	0.009	0.022	0.057
Dual 3-way	0.018	N/A	0.010	N/A



How To Order

Valves

R2 1 BB A Z4 M K 000 61

Series Identifier

- 02 = Spool/Sleeve with Body to Base Plug
- R2 = Rubber Packed Spool With Body to Base Plug

Port Size

- 1 = 1/8
- 2 = 1/4
- D = 5/32 (4mm) (Port type "K" only)
- F = 6mm (Port type "K" only)

Valve Type

- BW = Solenoid Pilot w/ Flush Non-Locking Manual Override & Differential Air Return
- BB = Double Solenoid Pilot w/ Flush Non-Locking Manual Override
- 00 = Blank Station

Function

- 4 = 2 Position, 4-Way
- 5 = 3 Position, 4-Way, Open Center, Dual Pressure
- 6 = 3 Position, 4-Way, Closed Center
- A = Dual 3-Way, A Normally Open - B Normally Open
- C = Dual 3-Way, A Normally Closed - B Normally Open
- D = Dual 3-Way, A Normally Closed - B Normally Closed
- P = Blank Station Plate

Voltage

- 61 = 24 VDC
- 00 = Use w/ Blank Station Plate

Options

- 11B = Flush Locking Override
- 14A = External Pilot Supply
- 000 = No Option

Port Type

- K = Push-in Fitting
- H = Barbed Fitting

Wiring Option

- M = Plug-In DC w/Light
- 0 = Blank Station

Mounting

- Z3 = Manifold Block, Side Ports Only, Single Solenoid Output
- Z4 = Manifold Block, Side Ports Only, Double Solenoid Output



2005 Series

single solenoid air pilot
2 position 4-way

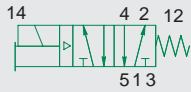

double solenoid air pilot
2 position 4-way

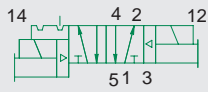

double solenoid air pilot
3 position 4-way
open center

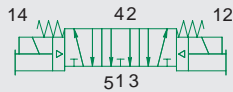

double solenoid air pilot
3 position 4-way
closed center

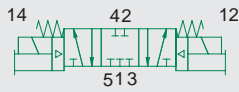

double solenoid air pilot
3 position 4-way
pressure center

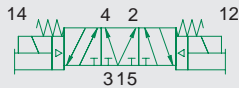

double solenoid
2 position dual 3-way
"14(A)" & "12(B)" NO

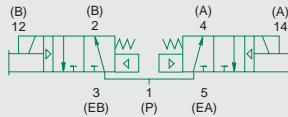

double solenoid
2 position dual 3-way
"14(A)" & "12(B)" NC

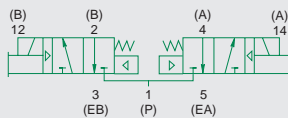

double solenoid
2 position dual 3-way
"14(A)" NC, "12(B)" NO

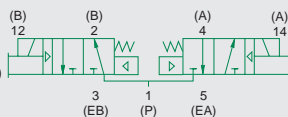

5 Ported, 2 and 3 position, 4-way, Spool & Sleeve
Cv: 0.56

Dual 3-Way Pack Spool Cv:0.56

- Solenoid air pilot actuated
- Low wattage coil
- DC solenoids polarity insensitive with spike suppression
- Plug together circuit boards eliminate internal wiring
- Integral recessed gaskets
- Interchangeable Push-in fittings to accommodate various tube sizes
- Simple conversion from internal to external pilot supply
- NEMA 4/IP65



Technical Data

VALVE DATA	ENGLISH	METRIC
Cv	0.56	0.56
Flow Capacity	26 SCFM @ 80 PSIG upstream pressure to atmosphere	552 NI/m @ 6 bar upstream to 5 bar downstream
Operating Pressure Range	28" Hg Vacuum to 150 PSIG	Vacuum to 10 bar
Operating Pressure Range – 3 Way	22" Hg Vacuum to 100 PSIG	Vacuum to 7 bar
Pilot Pressure Range	26 to 120 PSIG	1.8 to 8.2 bar
Pilot Pressure Range – 3 Way	26 to 100 PSIG	1.8 to 7 bar
Pilot Pressure Vacuum	50 to 100 PSIG	3.5 to 7 bar
Temperature Range (Ambient)	-10°F to +115°F	-23°C to +50°C

Operating Data

ALL SOLENOIDS ARE CONTINUOUS DUTY RATED	24 VDC	
Power (Watts)	1.35	
Holding Current (Amps)	0.056	
RESPONSE TIME IN SECONDS	ENERGIZE	DE-ENERGIZE
2 - Position, Single, Spring Return	0.014	0.016
2 - Position, Double, Detented	0.013	N/A
3 - Position, Spring Centered	0.014	0.016
Dual 3 Way	0.014	0.016



How to Order

Valves

051 BB 4 Z6 M N 000 61

Valve Series & Port Size
 051 = 1/8 (Threaded only)
 052 = 1/4 (Push-in only)
 05F = 6mm
 05H = 8mm

Valve Type
 BA = Single Solenoid Pilot, (Spring Return) w/flush Non-Locking Override
 BB = Double Solenoid Pilot w/Flush non-locking Override
 00 = Blank Station

Function
 4 = 2 Position, 4-way
 5 = 3 Position, 4-way Open Center
 6 = 3 Position, 4-way Closed Center
 7 = 3 Position, 4 way Pressure Center
 A = Dual 3-way, A Normally Open - B Normally Open
 B = Dual 3-way, Vacuum Service, A Normally Open - B Normally Open
 D = Dual 3-way, A Normally Closed - B Normally Closed
 E = Dual 3-way, Vacuum Service, A Normally Closed - B Normally Closed
 P = Blank Station Plate

Mounting
 Z1 = Manifold Block w/Side and Bottom Ports, Single Solenoid Internal Circuit Board
 Z2 = Manifold Block w/Side and Bottom Ports, Double Solenoid Internal Circuit Board
 Z5 = Z1 w/Speed Control
 Z6 = Z2 w/Speed Control
 R1 = Z1 w/ Ribbon Cable Connector
 R2 = Z2 w/ Ribbon Cable Connector
 R5 = Z5 w/ Ribbon Cable Connector
 R6 = Z6 w/ Ribbon Cable Connector

Voltage
 61 = 24 VDC
 00 = Use w/ Blank Station Plate

Options
 000 = No Option
 11B = Flush Locking Override
 11M = No Override

Port Type
 L = Push-In Fitting
 N = NPTF (1/8 only)
 G = G Tap (1/8 only)

Wiring Option
 M = Plug-In DC w/Light
 0 = Blank Station

Regulators

051 RS 1 Z1 J K 000 00

Valve Series & Port Size
 051 = 1/8
 052 = 1/4 (Push-in only)
 05F = 6mm
 05H = 8mm
 *Use for regulator unit only (Mounting = 00)

Regulator Type
 RS = Single Pressure to Port 1(P)
 RD = Dual Pressure to Ports 3 (EB) & 5 (EA)
 RE = Dual Pressure to Ports 4 (A) & 2 (B)
 RT = 2 Pressure Selector
 *For metric gauge replace R with E in 4th Digit.

Pressure Range
 1 = 10-130 PSIG (0.7-9 bar)
 3 = 3-30 PSIG (0.2-2 bar)
 4 = 5-60 PSIG (0.5-4 bar)

Mounting
 R1 = Z1 W/ Ribbon Cable Connector
 R2 = Z2 W/ Ribbon Cable Connector
 R5 = Z5 W/ Ribbon Cable Connector
 R6 = Z6 W/ Ribbon Cable Connector
 Z0 = Manifold Block w/Side and Bottom Ports, Transfer Board, Used w/RE Regulators RE only (no Z-board)
 Z1 = Manifold Block w/Side & Bottom Ports, Single Solenoid Internal Circuit Board
 Z2 = Manifold Block W/Side & Bottom Ports, Double Solenoid Internal Circuit Board
 Z5 = Z1 W/Speed Control
 Z6 = Z2 W/Speed Control

Options
 000 = No Option
 12H = Less Gauge
 16N = Jumper on 14 (A) End
 16P = Jumper on 12 (B) End
 16W = Top Facing Gauge
 61Y = Extended Gauge
 63D = 16W + 61Y Extended Top Facing Gauge

Port Type
 K = Push-In
 P = NPTF (1/8 only)
 Q = G Tap (1/8 only)

Wiring Option
 J = Plug-In Receptacle Ass'y

See Note Below



NOTE: Regulator gauges must be offset on alternating stations to prevent interference (see photo)

* Odd numbered stations will use either standard (no option) or top facing ("16W" option) gauges.

* Even numbered stations will use either extended standard ("61Y" option) or extended top facing ("63D" option) gauges.



2012 Series

single solenoid air pilot
2 position 4-way

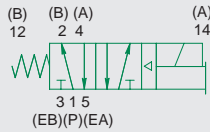

double solenoid air pilot
2 position 4-way

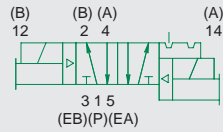

double solenoid air pilot
3 position 4-way
open center

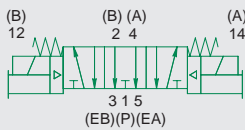

double solenoid air pilot
3 position 4-way
closed center

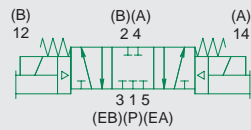

double solenoid air pilot
3 position 4-way
pressure center

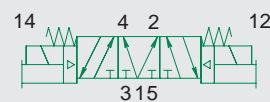

5 Ported, 2 and 3 position, 4-way, Spool & Sleeve
Cv: 1.2

- Solenoid air pilot actuated
- Low wattage coil
- DC solenoids polarity insensitive with spike suppression
- Plug together circuit boards eliminate internal wiring
- Integral recessed gaskets
- Interchangeable push-in fittings to accommodate various tube sizes
- Simple conversion from internal to external pilot
- NEMA 4/IP65



Technical Data

VALVE DATA	ENGLISH	METRIC
Cv	1.20	1.20
Flow Capacity	56 SCFM @ 80 PSIG upstream pressure to atmosphere	1180 NI/m @ 6 bar upstream to 5 bar downstream
Operating Pressure Range	28" Hg Vacuum to 150 PSIG	Vacuum to 10 bar
Pilot Pressure Range	26 to 120 PSIG	1.8 to 8.2 bar
Temperature Range (Ambient)	-10°F to + 115°F	-23°C to +50° C

Operating Data

ALL SOLENOIDS ARE CONTINUOUS DUTY RATED		24 VDC
Power (Watts)	2.5	
Holding Current (Amps.)	0.10	
RESPONSE TIME IN SECONDS	ENERGIZE	DE-ENERGIZE
2-Position, Single, Spring Return	0.010	0.020
2-Position, Double, Detented	0.010	N/A
3-Position, Spring Centered	0.010	0.020



How to Order

Valves

122 BB 4 Z6 M L 000 61

Valve Series & Port Size

122 = 1/4
123 = 3/8
12H = 8mm
12K = 10mm

Valve Type

BA = Single Solenoid Pilot, (Spring Return) w/Flush Non-Locking Override
BB = Double Solenoid Pilot w/Flush Non-Locking Override
00 = Blank Station

Function

4 = 2 Position, 4-way
5 = 3 Position, 4-way Open Center
6 = 3 Position, 4-way Closed Center
7 = 3 Position, 4-way Pressure Center
P = Blank Station Plate

Mounting

Z1 = Manifold Block w/Side and Bottom Ports, Single Solenoid Internal Circuit Board
Z2 = Manifold Block w/Side and Bottom Ports, Double Solenoid Internal Circuit Board
Z5 = Z1 w/Speed Control
Z6 = Z2 w/Speed Control
R1 = Z1 w/ Ribbon Cable Connector
R2 = Z2 w/ Ribbon Cable Connector
R5 = Z5 w/ Ribbon Cable Connector
R6 = Z6 w/ Ribbon Cable Connector

Voltage

61 = 24 VDC
00 = Use w/ Blank Station Plate

Special Options

000 = No Option
11B = Flush Locking Override
11M = No Override

Port Type

L = Push-in Fitting
N = NPTF
G = G Tap

Wiring Option

M = Plug-in DC w/Light
0 = Blank Station

Regulators

122 RS 3 Z1 J L 000 00

Valve Series & Port Size

122 = 1/4
123 = 3/8
12H = 8mm
12K = 10mm

Regulator Type

RS = Single Pressure to Port 1 (P)
RD = Dual Pressure to Ports 3 (EB) & 5 (EA)
RC = Dual Pressure w/Non-relieving Checks
RQ = Dual Pressure w/Relieving Checks
RE = Dual Pressure to Ports 4 (A) & 2 (B)
RT = 2 Pressure Selector
*For metric gauge, replace R with E in 4th digit.

Pressure Range

1 = 10-130 PSIG (0.7-9 bar)
3 = 3-30 PSIG (0.2-2 bar)
4 = 5-60 PSIG (0.5 - 4 bar)

Special Options

000 = No Option
12H = Less gauge
16N = Jumper on 14 (A) End
16P = Jumper on 12 (B) End
16W = Top Facing Gauge

Port Type

L = Push-In
N = NPTF
G = G Tap

Wiring Option

J = Plug-In Receptacle Ass'y
O = Non-Plug-In (Type RE only)

Mounting

R1 = Z1 w/Ribbon Cable Connector
R2 = Z2 w/Ribbon Cable Connector
R5 = Z5 w/Ribbon Cable Connector
R6 = Z6 w/Ribbon Cable Connector
Z0 = Manifold Block w/Side and Bottom Ports, Transfer Board, Used w/RE Regulators RE only (no Z-board)
Z1 = Manifold Block w/Side and Bottom Ports, Single Solenoid Internal Circuit Board
Z2 = Manifold Block w/Side and Bottom Ports, Double Solenoid Internal Circuit Board
Z5 = Z1 w/Speed Control
Z6 = Z2 w/Speed Control



2035 Series

single solenoid air pilot
2 position 4-way

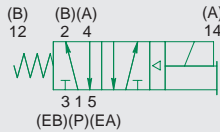

double solenoid air pilot
2 position 4-way

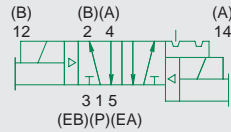

double solenoid air pilot
3 position 4-way
open center

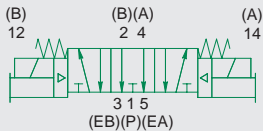

double solenoid air pilot
3 position 4-way
closed center

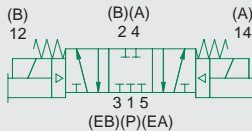

5 Ported, 2 and 3 position, 4-way, Spool & Sleeve
Cv: 3.5

- Solenoid air pilot actuated
- Low wattage coil
- DC solenoids polarity insensitive with spike suppression
- Plug together circuit boards eliminate internal wiring
- Integral recessed gaskets
- Simple conversion from internal to external pilot supply
- Designed to meet NEMA4/IP65
- Manifold connection allows disassembly at any station



Technical Data

VALVE DATA	ENGLISH	METRIC
Cv*	3.5*	3.5*
Flow Capacity	161 SCFM @ 80 PSIG upstream pressure to atmosphere	3500 NI/m @ 6 bar upstream pressure to 5 bar atmosphere
Operating Pressure Range	28" Hg Vacuum to 145 PSIG	Vacuum to 10 bar
Pilot Pressure Range	26.1 to 120 PSIG	1.8 to 8.2 bar
Temperature Range (Ambient)	-10°F to +115°F	-23°C to +50°C

Operating Data

ALL SOLENOIDS ARE CONTINUOUS DUTY RATED	24 VDC	
Power (Watts)	2.5	
Holding Current (Amps)	0.10	
RESPONSE TIME IN SECONDS**	ENERGIZE	DE-ENERGIZE
2 - Position, Single, Spring Return	.021	.067
2 - Position, Double, Detented	.017	N/A
3 - Position, Spring Centered	.021	.072

* Valve on 1/2 NPTF Sub-Plate

** Per ISO 12238 Standard



How to Order

Valves

353 BB 4 Z6 M N 000 61

Valve Series & Port Size

353 = 3/8
354 = 1/2

Valve Type

BA = Single Solenoid Pilot, (Spring Return)
w/Flush Non-Locking Override
BB = Double Solenoid Pilot w/Flush
Non-Locking Override
00 = Blank Station

Function

4 = 2 Position, 4-way
5 = 3 Position, 4-way Open Center
6 = 3 Position, 4-way Closed Center
P = Blank Station Plate

Mounting

Z1 = Manifold Block w/Side and Bottom Ports,
Single Solenoid Internal Circuit Board
Z2 = Manifold Block w/Side and Bottom Ports
Double Solenoid Internal Circuit Board
Z5 = Z1 w/Speed Control
Z6 = Z2 w/Speed Control
R1 = Z1 w/ Ribbon Cable Connector
R2 = Z2 w/ Ribbon Cable Connector
R5 = Z5 w/ Ribbon Cable Connector
R6 = Z6 w/ Ribbon Cable Connector

Voltage

61 = 24 VDC
00 = Use w/ Blank Station Plate

Special Options

000 = No Option
11B = Flush Locking Override
11M = No Override

Port Type

N = NPTF
G = G Tap

Wiring Option

M = Plug-in DC w/Light
0 = Blank Station

Regulators

353 RS 3 Z1 J N 000 00

Valve Series & Port Size

353 = 3/8
354 = 1/2

Regulator Type

RS = Single Pressure to Port 1 (P)
RD = Dual Pressure to Ports 3 (EB) & 5 (EA)
RC = Dual Pressure w/Non-relieving Checks
RQ = Dual Pressure w/Relieving Checks
RE = Dual Pressure to Ports 4 (A) & 2 (B)
RT = 2 Pressure Selector

Note: For metric gauge, replace R with E
in 4th digit.

Pressure Range

1 = 10-130 PSIG (0.7-9 bar)
3 = 3-30 PSIG (0.2-2 bar)
4 = 5-60 PSIG (0.5 - 4 bar)

Special Options

000 = No Option
12H = Less gauge
16N = Jumper on 14 (A) End
16P = Jumper on 12 (B) End
16W = Top Facing Gauge
000 = No Option

Port Type

N = NPTF
G = G Tap

Wiring Option

J = Plug-In Receptacle Assembly
O = Non-Plug-In (Type RE only)

Mounting

Z1 = Manifold Block w/Side and Bottom Ports,
Single Solenoid Internal Circuit Board
Z2 = Manifold Block w/Side and Bottom Ports,
Double Solenoid Internal Circuit Board
Z5 = Z1 w/Speed Control
Z6 = Z2 w/Speed Control
R1 = Z1 w/Ribbon Cable Connector
R2 = Z2 w/Ribbon Cable Connector
R5 = Z5 w/Ribbon Cable Connector
R6 = Z6 w/Ribbon Cable Connector



ISO 15407-2 18 mm Series

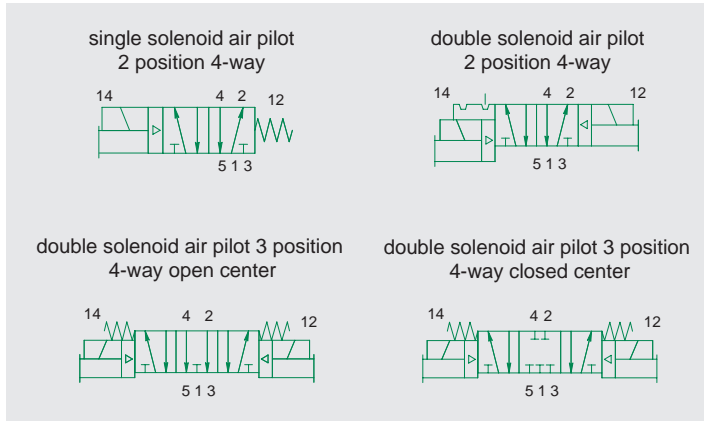

5 Ported, 2 and 3 position, 4-way, Spool & Sleeve
Cv: 0.56

- Solenoid air pilot actuated
- Low wattage coil
- DC solenoids polarity insensitive with spike suppression
- Plug together circuit boards eliminate internal wiring
- Integral recessed gaskets
- Interchangeable push-in fittings to accommodate various tube sizes
- Simple conversion from internal to external pilot
- NEMA 4/IP65



Technical Data - 18mm

VALVE DATA	ENGLISH	METRIC
Cv	0.56	0.56
Flow Capacity	26 SCFM @ 80 PSIG upstream pressure to atmosphere	552 NI/m @ 6 bar upstream to 5 bar downstream
Operating Pressure Range	28" Hg Vacuum to 150 PSIG	Vacuum to 10 bar
Pilot Pressure Range	26 to 120 PSIG	1.8 to 8.2 bar
Temperature Range (Ambient)	-10°F to + 115°F	-23°C to +50° C

Operating Data

ALL SOLENOIDS ARE CONTINUOUS DUTY RATED	24 VDC	
Power (Watts)	1.35	
Holding Current (Amps.)	0.056	
RESPONSE TIME IN SECONDS	ENERGIZE	DE-ENERGIZE
2-Position, Single, Spring Return	0.014	0.016
2-Position, Double, Detented	0.013	N/A
3-Position, Spring Centered	0.014	0.016



How to Order 15407-2 18 mm

Valves

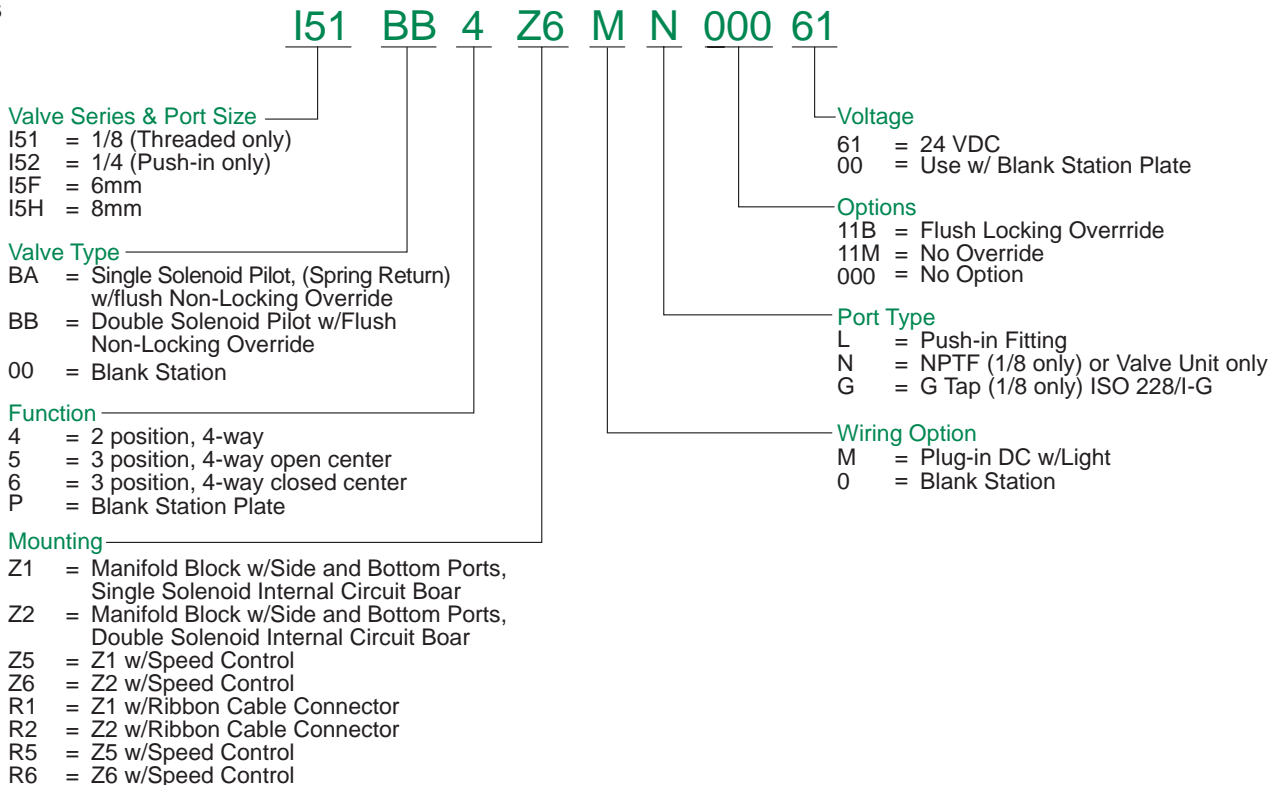

Regulators

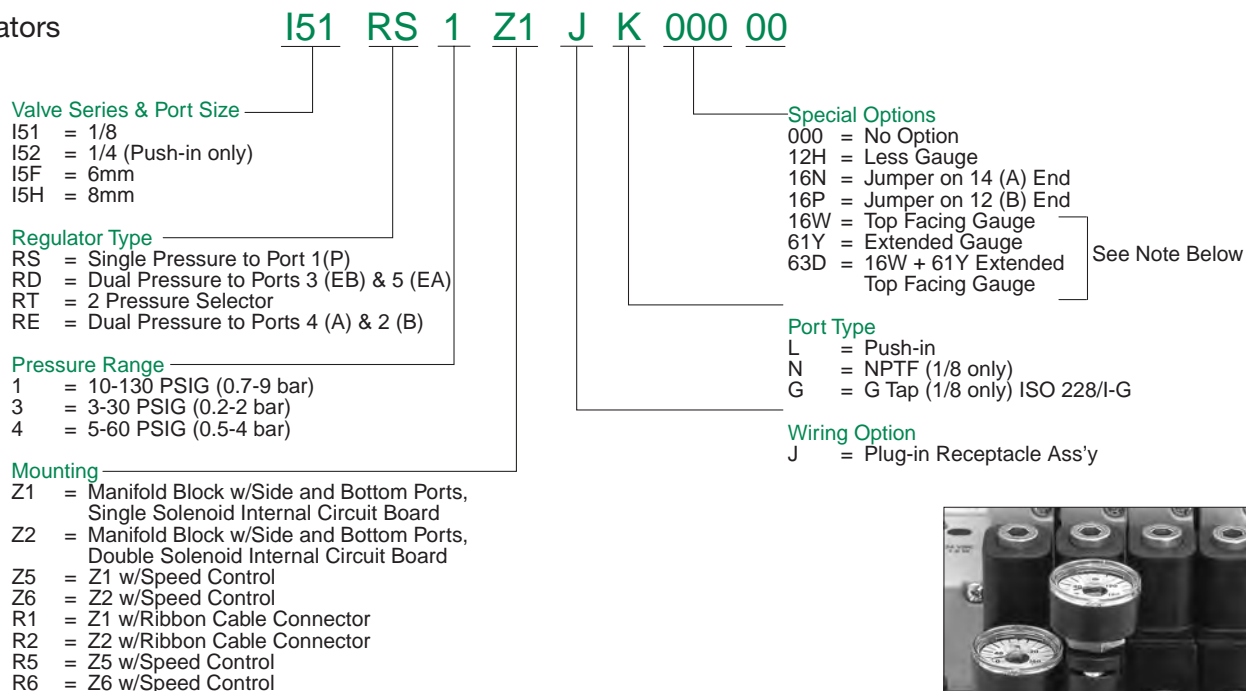

NOTE:

- * Regulator gauges must be offset on alternating stations to prevent interference (see photo)
- * Odd numbered stations will use either standard (no option) or top facing ("16W" option) gauges.
- * Even numbered stations will use either extended standard ("61Y" option) or extended top facing ("63D" option) gauges.



ISO 15407-2 26 mm Series

single solenoid air pilot
2 position 4-way

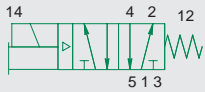

double solenoid air pilot
2 position 4-way

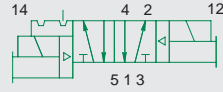

double solenoid air pilot 3 position
4-way open center

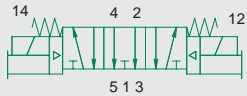

double solenoid air pilot 3 position
4-way closed center

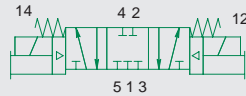

5 Ported, 2 and 3 position, 4-way, Spool & Sleeve
Cv: 1.2

- Solenoid air pilot actuated
- Low wattage coil
- DC solenoids polarity insensitive with spike suppression
- Plug together circuit boards eliminate internal wiring
- Integral recessed gaskets
- Interchangeable push-in fittings to accommodate various tube sizes
- Simple conversion from internal to external pilot
- Modular plug-together Fieldbus electronics
- NEMA 4/IP65



Technical Data - 26mm

VALVE DATA	ENGLISH	METRIC
Cv	1.20	1.20
Flow Capacity	56 SCFM @ 80 PSIG upstream pressure to atmosphere	1180 NI/m @ 6 bar upstream to 5 bar downstream
Operating Pressure Range	28" Hg Vacuum to 150 PSIG	Vacuum to 10 bar
Pilot Pressure Range	26 to 120 PSIG	1.8 to 8.2 bar
Temperature Range (Ambient)	-10°F to + 115°F	-23°C to +50° C

Operating Data

ALL SOLENOIDS ARE CONTINUOUS DUTY RATED	24 VDC	
Power (Watts)	2.5	
Holding Current (Amps.)	0.10	
RESPONSE TIME IN SECONDS	ENERGIZE	DE-ENERGIZE
2-Position, Single, Spring Return	0.010	0.020
2-Position, Double, Detented	0.010	N/A
3-Position, Spring Centered	0.010	0.020



How to Order 15407-2 26 mm

Valves

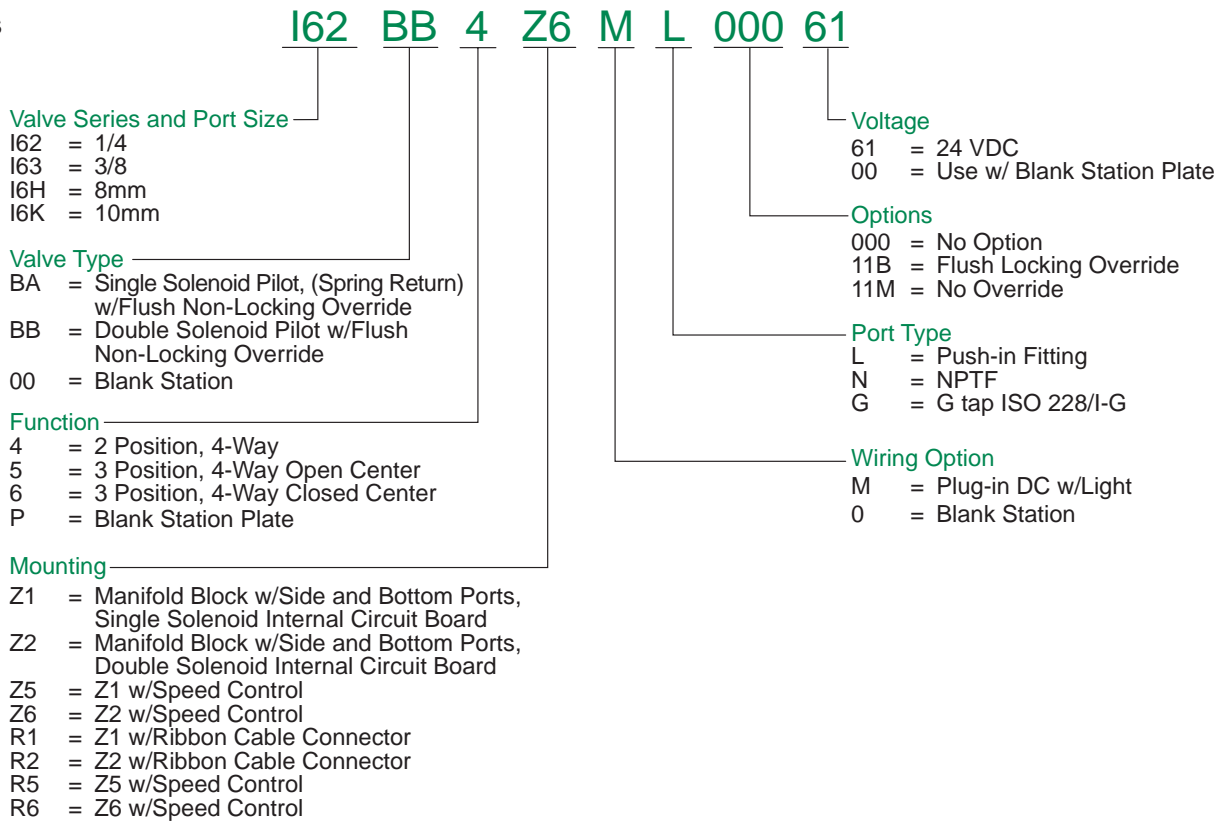

Regulators

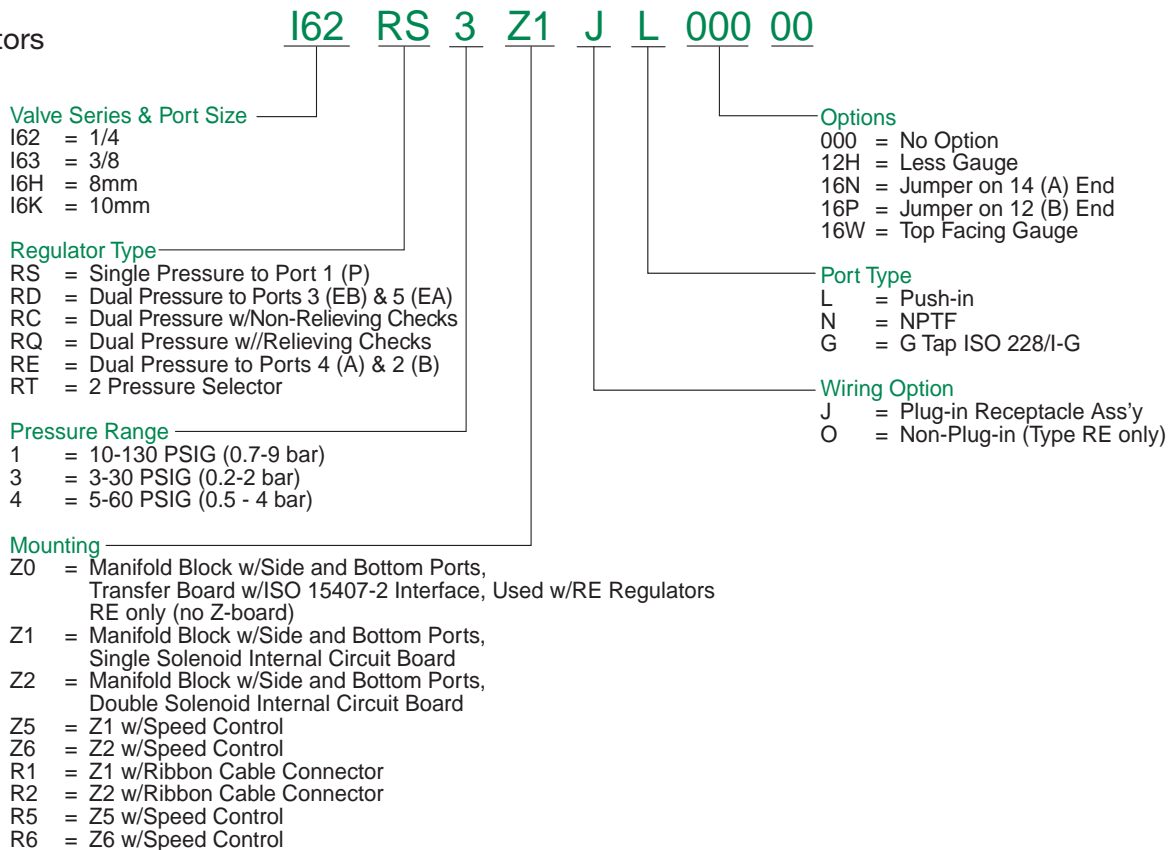



ISO 5599/2 Series

Direct Solenoid Actuated

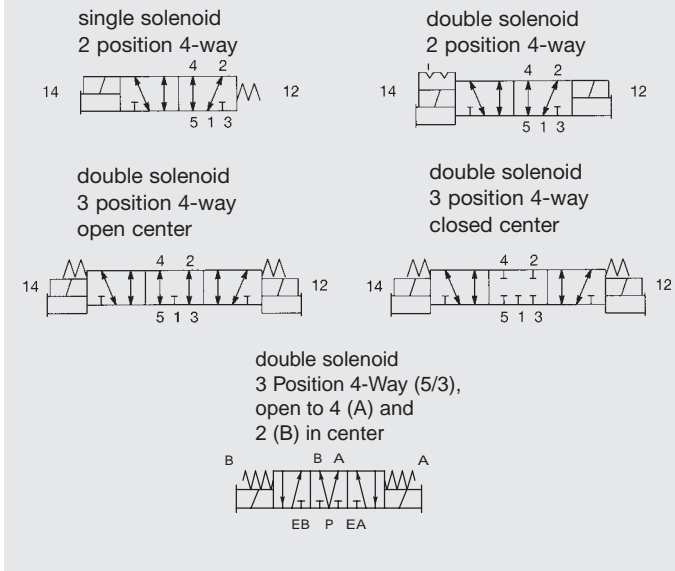

Solenoid Pilot Actuated

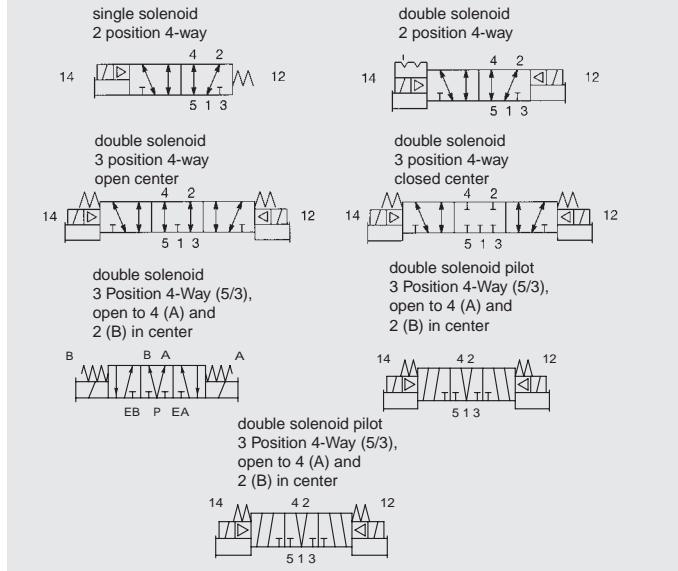

5 Ported, 4-way, 2 and 3 position, Spool & Sleeve,
Cv: 1.2 to 5.3

- Direct and Solenoid Pilot Actuated
- Complies with ISO Standard 5599/2- Sizes 1, 2 & 3
- NEMA 4/IP 65



Technical Data

VALVE DATA	DIRECT ACTING		SOLENOID PILOT ACTUATED	
	ENGLISH	METRIC	ENGLISH	METRIC
Cv	Size 1 1.2 Size 2 2 Size 3 NA	1.2 2 NA	1.3 2.9 5.3	1.3 2.9 5.3
Flow Capacity	Size 1 55.5 SCFM Size 2 101.7 SCFM Size 3 NA	1181 NI/m 2168 NI/m NA	60.1 SCFM 134.0 SCFM 245.0 SCFM	1280 NI/m 2857 NI/m 5222 NI/m
Main valve operating pressure range - All sizes	80 PSIG upstream pressure to atmosphere	6 bar upstream to 5 bar downstream	80 PSIG upstream pressure to atmosphere	6 bar upstream to 5 bar downstream
Pilot pressure range - All sizes	28" Hg to 232 PSIG	Vacuum to 16 bar	15 to 125 PSIG	1 to 8.6 bar
Temperature Range (Ambient) - All sizes	-10°F to +115°F	-23°C to +50°C	-10°F to +115°F	-23°C to +50°C

Operating Data - All solenoids continuous duty rated

ALL SOLENOIDS ARE CONTINUOUS DUTY RATED	24 VDC DIRECT ACTING		24 VDC SOLENOID PILOT	
	SIZES 1 & 2	SIZE 3	SIZES 1 & 2	SIZE 3
Power (Watts) - All Sizes	6.0	NA	4.0	4.0
Holding Current (Amps)	.25	NA	0.016	0.016
In-Rush Current (Amps) - All Sizes	NA	NA	NA	NA

RESPONSE TIME IN SECONDS	DIRECT ACTING				SOLENOID PILOT ACTUATED					
	ENERGIZE (SEC)		DE-ENERGIZE (SEC)		ENERGIZE (SEC)			DE-ENERGIZE (SEC)		
	SIZES 1 & 2	SIZE 3	SIZES 1 & 2	SIZE 3	SIZE 1	SIZE 2	SIZE 3	SIZE 1	SIZE 2	SIZE 3
2-Position, Single, Spring Return	0.038	NA	0.012	NA	0.013	0.013	0.020	0.036	0.060	0.066
2-Position, Double, Detented	0.012	NA	NA	NA	0.013	0.013	0.020	NA	NA	NA
3-Position, Spring Centered	0.038	NA	NA	NA	0.013	0.013	0.020	0.036	0.060	0.066



How to Order

Valves

I24 BA 4 Z1 M P 000 61

Valve Series and Port Size

- I12 = ISO 5599/2 Size 1 1/4
- I13 = ISO 5599/2 Size 1 3/8
- I23 = ISO 5599/2 Size 2 3/8
- I24 = ISO 5599/2 Size 2 1/2
- I34* = ISO 5599/2 Size 3 1/2
- I35* = ISO 5599/2 Size 3 3/4

First letter = "14" Actuator

Second letter = "12" Actuator

- BA = Solenoid Pilot w/Spring Return
- BB = Double Solenoid
- BW = Solenoid Pilot w/Differential Air Return
- SA = Direct Solenoid w/Spring Return
- SS = Double Direct Solenoid
- 00 = Blank Station

Function

- 4 = 2 Position, 4-Way
- 5 = 3 Position, 4-Way Open Center
- 6 = 3 Position, 4-Way Closed Center
- 7 = 3 Position 4-Way (5/3), Open to 4 (A) and 2 (B) in Center
- P = Blank Station Plate

Mounting

- Z1 = Manifold Block w/Side and Bottom Ports, Single Solenoid Internal Circuit Board
- Z2 = Manifold Block w/Side and Bottom Ports, Double Solenoid Internal Circuit Board
- Z5 = Z1 w/Speed Control
- Z6 = Z2 w/Speed Control
- R1 = Z1 w/Ribbon Cable Connector
- R2 = Z2 w/Ribbon Cable Connector
- R5 = Z5 w/Ribbon Cable Connector
- R6 = Z6 w/Ribbon Cable Connector

Voltage

- 61 = 24 VDC
- 00 = Use w/Blank Station Plate

Options

- 000 = No Option
- 11B = Flush Locking Manual Override
- 11Z = Extended Locking Manual Override (Direct Acting Only)
- 12A = Viton Seals on Sleeve Assembly
- 12B = Lubricant Free Assembly
- 14C = Internal Pilot Supply from Port 3 (Solenoid Pilot Only)
- 14D = Internal Pilot Supply from Port 5 (Solenoid Pilot Only)
- 14X = External Pilot Supply

Port Type

- 0 = NPTF (Direct Solenoid Valves)
- G = G Tap (Direct Solenoid Valves) (conforms to ISO standards 1179-1 and 228-1)
- P = NPTF (Solenoid Pilot Valves)
- Q = G Tap (Solenoid Pilot Valves) (conforms to ISO standards 1179-1 and 228-1)

Wiring Option

- M = Plug-in DC w/Light
- 0 = Blank Station

Note: Standard for all ISO 5599/2 Solenoid Pilot Valve Series is internal pilot supply from port #1.
*Not available in direct operated SA and SS Series

Regulators

I24 RS 1 Z1 J P 000 00

Valve Series and Port Size

- I12 = ISO 5599/2 Size 1 1/4"
- I13 = ISO 5599/2 Size 1 3/8"
- I23 = ISO 5599/2 Size 2 3/8"
- I24 = ISO 5599/2 Size 2 1/2"
- I34 = ISO 5599/2 Size 3 1/2"
- I35 = ISO 5599/2 Size 3 3/4"

Regulator Type

- RS = Single Pressure to Port #1 (P)
- RD* = Dual Pressure to Ports #3 (EB) & #5 (EA)
- RC* = Dual Pressure w/Non-relieving Checks Air Return (Sizes 2 & 3 Only)
- RQ* = Dual Pressure w/Relieving Checks
- RE = Dual Pressure, External Outlet

*Solenoid pilot valves used with RC, RD & RQ regulators must have the pilot supply from other than internally from port #1 (P)

Pressure Range

- 1 = 10 - 130 PSIG (0.7 - 9 bar)
- 3 = 3 - 30 PSIG (0.2 - 2 bar)
- 4 = 5 - 60 PSIG (0.3 - 4.1 bar)
- 6 = 20 - 250 PSIG (1.4 - 17 bar)

Options

- 000 = No Option
- 16N = Jumper on 14 (A) End
- 16P = Jumper on 12 (B) End

Port Type

- P = NPTF
- Q = G Tap

Wiring Option

- J = Plug-In Recepticle
- O = Non Plug-In Type RE Only

Mounting

- Z0 = Manifold Block w/Side and Bottom Ports Transfer Board, Used w/RE Regulator
- Z1 = Manifold Block with Side and Bottom Ports, Single Solenoid Internal Circuit Board
- Z2 = Manifold Block with Side and Bottom Ports, Double Solenoid Internal Circuit Board
- Z5 = Z1 w/Speed Control
- Z6 = Z2 w/Speed Control
- R1 = Z1 w/Ribbon Cable Connector
- R2 = Z2 w/Ribbon Cable Connector
- R5 = Z5 w/Ribbon Cable Connector
- R6 = Z6 w/Ribbon Cable Connector



G3 Power Cables & Connectors

7/8" MINI Cables

4 Pin Cables for DeviceNet, DeviceLogix, Ethernet, Modbus TCP, CANopen, and Sub-Bus

7/8" MINI STRAIGHT 4 PIN FEMALE SINGLE ENDED CABLE, EURO COLOR CODE

MC0405MAC0000000 – 5 Meter

MC0410MAC0000000 – 10 Meter



7/8" MINI 90° 4 PIN FEMALE SINGLE ENDED CABLE, EURO COLOR CODE

MD0405MAC0000000 – 5 Meter

MD0410MAC0000000 – 10 Meter



5 Pin Cables for PROFIBUS DP and PROFINET

7/8" MINI STRAIGHT 5 PIN FEMALE SINGLE ENDED CABLE, EURO COLOR CODE

MC0505MAG0000000 – 5 Meter

MC0510MAG0000000 – 10 Meter



7/8" MINI 90° 5 PIN FEMALE SINGLE ENDED CABLE, EURO COLOR CODE

MD0505MAG0000000 – 5 Meter

MD0510MAG0000000 – 10 Meter



7/8" MINI Field Wireable Connectors

4 Pin Connectors for DeviceNet, DeviceLogix, Ethernet, Modbus TCP, CANopen, and Sub-Bus

7/8" MINI STRAIGHT 4 PIN FEMALE FIELD WIREABLE CONNECTOR

MC04F90000000000 – Cable Gland – One size fits all



7/8" MINI 90° 4 PIN FEMALE FIELD WIREABLE CONNECTOR

MD04F20000000000 – PG 9 Cable Gland



5 Pin Connectors for PROFIBUS DP and PROFINET

7/8" MINI STRAIGHT 5 PIN FEMALE FIELD WIREABLE CONNECTOR

MC05F90000000000 – Cable Gland – One size fits all



7/8" MINI 90° 5 PIN FEMALE FIELD WIREABLE CONNECTOR

MD05F20000000000 – PG 9 Cable Gland





M12 to 7/8" MINI Cable

4 Pin Cable for Sub-Bus Power



M12 STRAIGHT 4 PIN MALE TO 7/8" MINI 4 PIN FEMALE EXTENSION

TA0401MA0MC0471T – 1 Meter

TA0405MA0MC0471T – 5 Meter

TA0410MA0MC0471T – 10 Meter

M12 Cables

4 Pin Cables for Sub-Bus Power



M12 STRAIGHT 4 PIN FEMALE SINGLE ENDED CABLE, EURO COLOR CODE

TC0405MAE0000000 – 5 Meter

TC0410MAE0000000 – 10 Meter



M12 90° 4 PIN FEMALE SINGLE ENDED CABLE, EURO COLOR CODE

TD0405MAE0000000 – 5 Meter

TD0410MAE0000000 – 10 Meter



M12 STRAIGHT 4 PIN MALE TO FEMALE CABLE EXTENSION

TC0401MAETA04000 – 1 Meter

TC0405MAETA04000 – 5 Meter

TC0410MAETA04000 – 10 Meter

M12 Field Wireable Connectors

4 Pin Connectors for Sub-Bus Power



M12 STRAIGHT 4 PIN FEMALE FIELD WIREABLE CONNECTOR

TC04F10000000000 – PG 7 Cable Gland

TC04F20000000000 – PG 9 Cable Gland



M12 90° 4 PIN FEMALE FIELD WIREABLE CONNECTOR

TD04F10000000000 – PG 7 Cable Gland

TD04F20000000000 – PG 9 Cable Gland



Pin Out and Technical Data

M12 Cable - Pin Out / Euro Color Code (Male View)

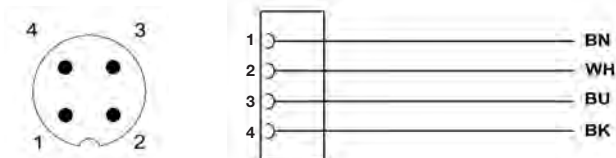

7/8" MINI Cable - Pin Out / Euro Color Code (Male View)

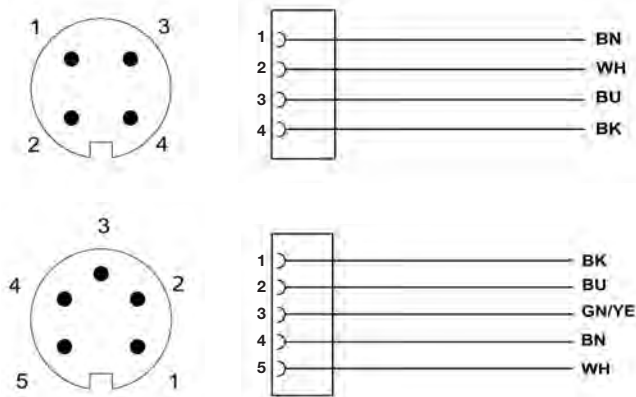

TECHNICAL DATA	M12	7/8" MINI
Molded Body / Insert	Cable = PVC Field Wireable = Polyamide	Cable = PVC Field Wireable = Polyamide or PBT
Coupling Nut	Nickel Copper Alloy	Black Anodized Aluminum
Cable Jacket Material	PVC	PVC
Cable O.D.	7.4mm	7.4mm (4 Pin & 5 Pin)
Voltage Rating (Nominal)	250 V Max. @ 105° C	250 V Max. @ 105° C
Current Rating	Cables = 4.0 Amps Field Wireable = 4.0 Amps	Cables = 5.5 Amps Field Wireable = 8.0 Amps
Degree of Protection	IP67 (mated)	IP67 (mated)
Operating Temperature	-25° C - 85° C	-40° C - 85° C
Conductor Gauge	Cable = 18 AWG	Cable = 18 AWG
Bend Radius	Cable = 74mm	Cable = 74mm (4 Pin & 5 Pin)
Maximum Wire AWG	Field Wireable = 18 AWG	Field Wireable = 16 AWG
Wire Connection	Field Wireable = Screw Terminal	Field Wireable = Screw Terminal
PG 7 Range	4-6 mm	N/A
PG 9 Range	6-8 mm	5-13 mm – One size fits all
PG 13.5 Range	N/A	5-13 mm – One size fits all



7/8" MINI Drop Cables

7/8" MINI STRAIGHT 5 PIN FEMALE SINGLE ENDED CABLE - SHIELDED

MC0505MGD0000000 - 5 Meter
MC0510MGD0000000 - 10 Meter



M12 Drop Cables

M12 STRAIGHT 5 PIN FEMALE SINGLE ENDED CABLE - SHIELDED

TC0505MGD0000000 - 5 Meter
TC0510MGD0000000 - 10 Meter



7/8" MINI 3 Way "T"

3 WAY 7/8" MINI "T"
MC0500000MT05000



Terminating Resistors "TR"

7/8" MINI & M12 STRAIGHT 5 PIN MALE TERMINATORS

TA05TR0000000000 - M12 Male
MA05TR0000000000 - MINI Male



7/8" MINI Field Wireable Connectors

7/8" MINI STRAIGHT 5 PIN FIELD WIREABLE CONNECTORS

MC05F90000000000 - Female - Cable Gland - One size fits all
MA05F90000000000 - Male - Cable Gland - One size fits all

MINI Cable - Pin Out / Color Code
(Male View)

M12 Cable - Pin Out / Color Code
(Male View)

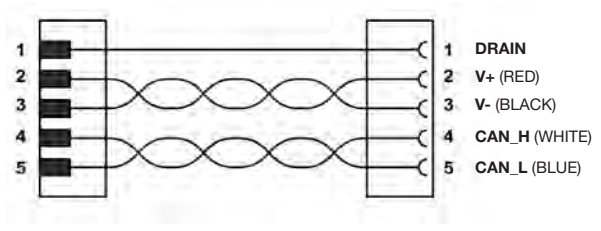
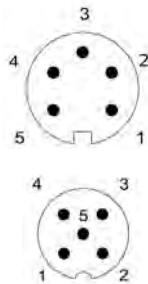

TECHNICAL DATA	CABLE	T & TR	FIELD WIREABLE
Molded Body / Insert	PVC	PVC	Body = Glass Filled Polyamide
Coupling Nut	Nickel Plated Brass or Anodized Aluminum	Clear Anodized Aluminum	Black Anodized Aluminum
Cable Jacket Material	PVC	N/A	N/A
Cable O.D.	MINI = 8mm M12 = 8mm	N/A	5-13mm - One size fits all
Voltage Rating (Nominal)	150 Volts	T =300 Volts	600 Volts
Current Rating	MINI =4.0 Amps MR = 3.0 Amps	T = 8.0 Amps TR = NA	8.0 Amps
Degree of Protection	IP65 (mated)	IP65 (mated)	IP65 (mated)
Operating Temperature	-40° C - 80° C	-40° C - 105° C	-40° C - 90° C
Conductor Gauge	22 AWG Power 24 AWG Signal	N/A	16-22 AWG
Bend Radius	Cable = 72mm	N/A	N/A
Wire Connection	NA	N/A	Screw Terminal



G3 Ethernet Cables & Connectors



M12 D-Coded Cables

M12 STRAIGHT 4 PIN MALE D-CODED SINGLE ENDED CABLE - SHIELDED

QA0405MK00000000 – 5 Meter

QA0410MK00000000 – 10 Meter

M12 STRAIGHT 4 PIN MALE D-CODED TO MALE RJ45 CABLE - SHIELDED

QA0405MK0VA04000 – 5 Meter

QA0410MK0VA04000 – 10 Meter

M12 STRAIGHT 4 PIN MALE D-CODED TO RJ45 FEMALE SOCKET CONVERTOR - SHIELDED

QA04D2MK0VC04000 – 0.2 Meter

M12 D-Coded Field Wireable Connectors

M12 STRAIGHT 4 PIN MALE D-CODED FIELD WIREABLE CONNECTOR

QA04F20000000000 – PG 9 Cable Gland – Screw Terminal

M12 STRAIGHT 4 PIN MALE D-CODED FIELD WIREABLE CONNECTOR W/IDC

QA04F2000000071N – PG 9 Cable Gland - IDC

RJ45 Field Wireable Connector

RJ45 FIELD WIREABLE CONNECTOR WITH IDC

VA08F2000000071N – PG 9 Cable Gland

M12 D-Coded Cable - Pin Out / Color Code (Male View)

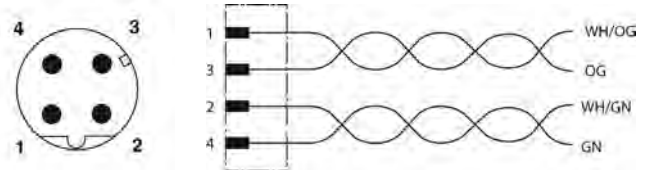

TECHNICAL DATA	CABLE	RJ45 FIELD WIREABLE	FIELD WIREABLE
Molded Body / Insert	TPU, PA, PA66	Housing = PA Carrier = PC	Body = Nickel Plated Zinc Insert = PA 66
Coupling Nut	Nickel Plated Zinc or Brass	N/A	Nickel Plated Brass
Cable Jacket Material	PUR or PVC	N/A	N/A
Cable O.D.	0.67 to 8.0 mm	4.5 to 8.0 mm	6.0 to 8.0 mm
Voltage Rating (Nominal)	42 Volts	N/A	60 Volts
Current Rating	1.5 Amps	1.75 Amps	Screw 4.0 Amps IDC 1.75 Amps
Degree of Protection	IP65 (mated)	IP20 (mated)	IP65 (mated)
Operating Temperature	-20° C - 60° C	-20° C - 70° C	-40° C - 85° C
Conductor Gauge	26 & 24 AWG	26-22 AWG Solid/Stranded	Screw 24-18 AWG IDC 26-22 AWG
Bend Radius	40mm	N/A	N/A
Wire Connection	NA	IDC	IDC, Screw Terminal



G3 PROFIBUS Cables & Connectors



M12 Reverse Key B-Coded Cables

M12 STRAIGHT 5 PIN MALE REVERSE KEY SINGLE ENDED CABLE - SHIELDED

RA0505MHP0000000 – 5 Meter

RA0510MHP0000000 – 10 Meter



M12 STRAIGHT 5 PIN FEMALE REVERSE KEY SINGLE ENDED CABLE - SHIELDED

RC0505MHP0000000 – 5 Meter

RC0510MHP0000000 – 10 Meter



M12 STRAIGHT 5 PIN MALE TO FEMALE REVERSE KEY EXTENSION CABLE

RC0505MHPRC05000 – 5 Meter

RC0510MHPRC05000 – 10 Meter



M12 Reverse Key B-Coded Field Wireable Connectors

M12 STRAIGHT 5 PIN MALE REVERSE KEY FIELD WIREABLE CONNECTOR

RA05F200P0000000 – PG 9 Cable Gland



M12 STRAIGHT 5 PIN FEMALE REVERSE KEY FIELD WIREABLE CONNECTOR

RC05F200P0000000 – PG 9 Cable Gland



M12 Reverse Key B-Coded Terminating Resistor

M12 STRAIGHT 5 PIN MALE REVERSE KEY TERMINATING RESISTOR

RA05TR00000000000 - Male



M12 Reverse Key B-Coded "T"

M12 REVERSE KEY 5 PIN BUS "T"

RA050000PRT05000

M12 Reverse Key B-Coded Cable Pin Out / Color Code (Male View)

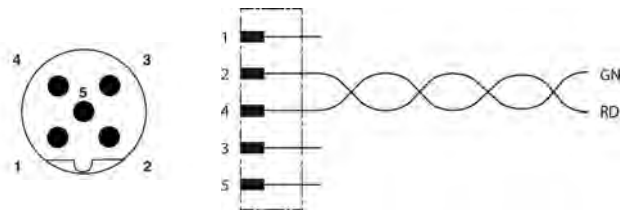

TECHNICAL DATA	CABLE	T & TR	FIELD WIREABLE
Molded Body / Insert	TPU	T = PUR TR = TPU	Body = Nickel Plated Zinc Insert = PA 66
Coupling Nut	Nickel Plated Zinc	Nickel Plated Zinc or Brass	Nickel Plated Brass
Cable Jacket Material	PUR	N/A	N/A
Cable O.D.	7.4 mm	N/A	8.5 mm Max.
Voltage Rating (Nominal)	250 volts	60 Volts	60 Volts
Current Rating	4.0 Amps	4.0 Amps	4.0 Amps
Degree of Protection	IP65 (mated)	IP65 (mated)	IP 65 (mated)
Operating Temperature	-20° C - 80° C	-20° C - 80° C	-40° C - 85° C
Conductor Gauge	24 AWG	N/A	18 AWG Maximum
Bend Radius	Cable = 78mm	N/A	N/A
Wire Connection	N/A	N/A	Screw Terminal



G3 I/O Cables & Connectors

I/O Cables with SPEEDCON Connector Technology



M12 STRAIGHT 4 PIN MALE SINGLE ENDED CABLE, EURO COLOR CODE

TA04E5MIE000071P – 1.5 Meter

TA0403MIE000071P – 3 Meter

TA0405MIE000071P – 5 Meter



M12 90° 4 PIN MALE SINGLE ENDED CABLE, EURO COLOR CODE

TB04E5MIE000071P – 1.5 Meter

TB0403MIE000071P – 3 Meter

TB0405MIE000071P – 5 Meter



M12 STRAIGHT 4 PIN MALE TO FEMALE CABLE EXTENSION

TC04E5MIETA0471P – 1.5 Meter

TC0403MIETA0471P – 3 Meter



M12 STRAIGHT 3 PIN MALE TO M8 3 PIN STRAIGHT FEMALE EXTENSION

TC03E5MIEPA0371P – 1.5 Meter

TC0303MIEPA0371P – 3 Meter

I/O Connectors



M12 STRAIGHT 4 PIN MALE FIELD WIREABLE CONNECTOR, IDC CONNECTION

TA04F2000000081E – PG 9 Cable Gland w/ SPEEDCON connector technology



M12 STRAIGHT 4 PIN MALE FIELD WIREABLE CONNECTOR, SCREW TERMINAL

TA04F10000000000 – PG 7 Cable Gland

TA04F20000000000 – PG 9 Cable Gland



M12 90° 4 PIN MALE FIELD WIREABLE CONNECTOR, SCREW TERMINAL

TB04F10000000000 – PG 7 Cable Gland

TB04F20000000000 – PG 9 Cable Gland

I/O Splitters



M12 TO M12 “Y” SPLITTER, 21MM SPACING

TA050000JC05000



M12 TO M8 “Y” SPLITTER

TA040000KC03000



M12 CABLE SPLITTER, 2 STRAIGHT M12 FEMALE CONNECTORS

- TA04D3MIEJC04000 – 0.3 Meter
- TA04E5MIEJC04000 – 1.5 Meter
- TA0403MIEJC04000 – 3.0 Meter



M12 CABLE SPLITTER, 2 STRAIGHT M8 FEMALE CONNECTORS

- TA04D3MIEKC03000 – 0.3 Meter
- TA04E5MIEKC03000 – 1.5 Meter
- TA0403MIEKC03000 – 3.0 Meter



WIRE STRIPPER TOOL

140-1097

I/O Cable Connector Pin Out Diagrams

M12 Cable - Pin Out / Color Code
TA04XXMIE0000000, TB04XXMIE0000000
(Male View)



M12 Cable - Pin Out / Color Code
TC03XXMIEPA0371P
(Male to Female View)

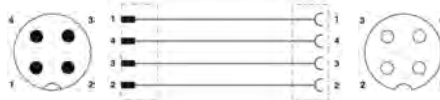

M12 Cable - Pin Out / Color Code
TC03XXMIEPA0371P
(Male to Female View)

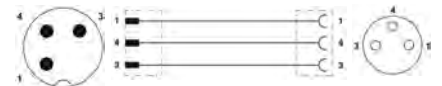

M12 to M12 "Y" Splitter - Pin Out
TA0500000JC05000
(Male to Female View)

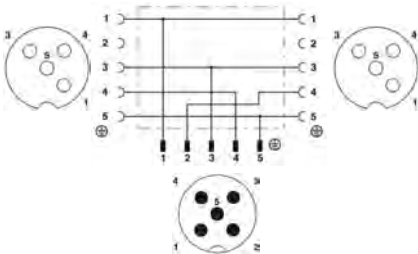

M12 to M8 "Y" Splitter - Pin Out
TA0400000KC03000
(Male to Female View)

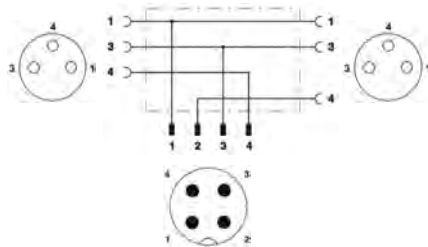

M12 Field Wireable (IDC) - Pin Out
TA04F2000000081E (SPEEDCON)
(Male View)



M12 to M12 Cable Splitter - Pin Out
TA04XXMIEJC04000
(Male to Female View)

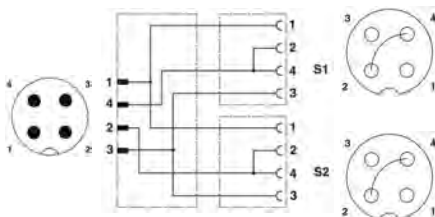

M12 to M8 Cable Splitter - Pin Out
TA04XXMIEKC03000
(Male to Female View)

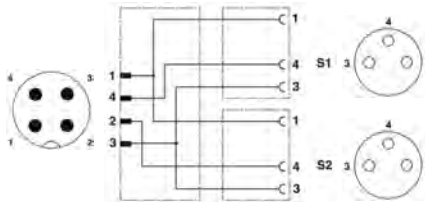

Note:
XX denotes allowable length
See pages 42 and 43.



Cable and Connector Technical Data

TECHNICAL DATA	M12 CABLES	M12/M8 CABLES	M12 CONNECTORS
Molded Body / Insert	TPU	TPU	Polyamide (or) PA 66
Coupling Nut	Nickel Plated Zinc	Nickel Plated Zinc	Nickel Plated Zinc
Cable Jacket Material	PUR	PUR	NA
Cable O.D.	4.70 mm	4.70 mm	PG7 4.0 to 6.0 mm PG9 4.0 to 8.0 mm
Voltage Rating	250 Volts	60 Volts	50 Volts
Current Rating (Cond.)	4.0 Amps	3.0 Amps	4.0 Amps
Degree of Protection	IP65 (mated)	IP65 (mated)	IP67 (mated)
Operating Temperature	-25° C to 80° C (fixed instl.)	-25° C to 80° C (fixed instl.)	-25° C to 80° C
Conductor Gauge	22 AWG	22 AWG	22 AWG Min. 18 AWG Max.
Bend Radius	47 mm	47 mm	NA

TECHNICAL DATA	I/O "Y" SPLITTER	I/O CABLE SPLITTER
Molded Body / Insert	TPU	TPU
Coupling Nut	Nickel Plated Zinc	Nickel Plated Zinc
Cable Jacket Material	NA	PUR
Cable O.D.	NA	4.40 mm
Voltage Rating	60 Volts	60 Volts
Current Rating (Cond.)	3.0 Amps	3.0 Amps
Degree of Protection	IP67 (mated)	IP67 (mated)
Operating Temperature	-25° C to 90° C	-25° C to 80° C
Conductor Gauge	NA	22 AWG or 24 AWG
Bend Radius	NA	44 mm

TECHNICAL DATA	WIRE STRIPPER
Use with	PVC Insulation
Stripping Range	28 AWG to 10 AWG
Cutting Range (Flexible)	10 AWG
Cutting Range (Rigid)	12 AWG



Sub-Bus Cables



M12 STRAIGHT 5 PIN MALE TO FEMALE SUB-BUS CABLE - SHIELDED

TA0501MGDTC0571P – 1 Meter

TA0505MGDTC0571P – 5 Meter

TA0510MGDTC0571P – 10 Meter



M12 STRAIGHT 5 PIN FEMALE FIELD WIREABLE CONNECTOR, SPRING CAGE

TC05F2000000071V – PG9



M12 STRAIGHT 5 PIN MALE FIELD WIREABLE CONNECTOR, SPRING CAGE

TA05F2000000071V – PG9



M12 90° 5 PIN FEMALE FIELD WIREABLE CONNECTOR, SPRING CAGE

TD05F2000000071V – PG9



M12 90° 5 PIN MALE FIELD WIREABLE CONNECTOR, SPRING CAGE

TB05F2000000071V – PG9



BULK SUB-BUS CABLE

*NOTE

000550MGD0005000 – 50 Meter Length

0005A0MGD0005000 – 100 Meter Length

* Note:

Length of field wired cables should not exceed the maximum length of 30 meters for total sub-bus communications link. See appropriate technical manual for sub-bus length requirements. The cable assemblies and Bulk cable are the only approved cables for the G3 Sub-Bus link. See technical document TDG3SBWD1-0EN for proper installation and wiring of field wireable connectors.

Technical Data

TECHNICAL DATA	CABLE	CONNECTORS	BULK CABLE
Molded Body / Insert	TPU	Zinc - Nickel Plated	N/A
Coupling Nut	Zinc - Nickel Plated	Brass - Nickel Plated	N/A
Cable Jacket Material	PUR	N/A	Gray RAL 7001
Cable O.D.	6.70 mm	N/A	6.70 mm
Voltage Rating (Nominal)	60 Volts	60 Volts	60 Volts
Current Rating	4.0 Amps	4.0 Amps	4.0 Amps
Degree of Protection	IP65 (mated)	IP65 (mated)	IP65 (terminated)
Operating Temperature	-40° C - 80° C	-40° C - 80° C	-20° C - 75° C
Conductor Gauge	24 AWG Signal 22 AWG Power	26-20 AWG	24 AWG Signal 22 AWG Power
Bend Radius	67 mm	N/A	67 mm
No. of Bending Cycles	5 Million	N/A	5 Million



G3 Sub-Bus Cables

Example Sub-Bus Layout and Cabling (DeviceNet™ / CANopen® Network)

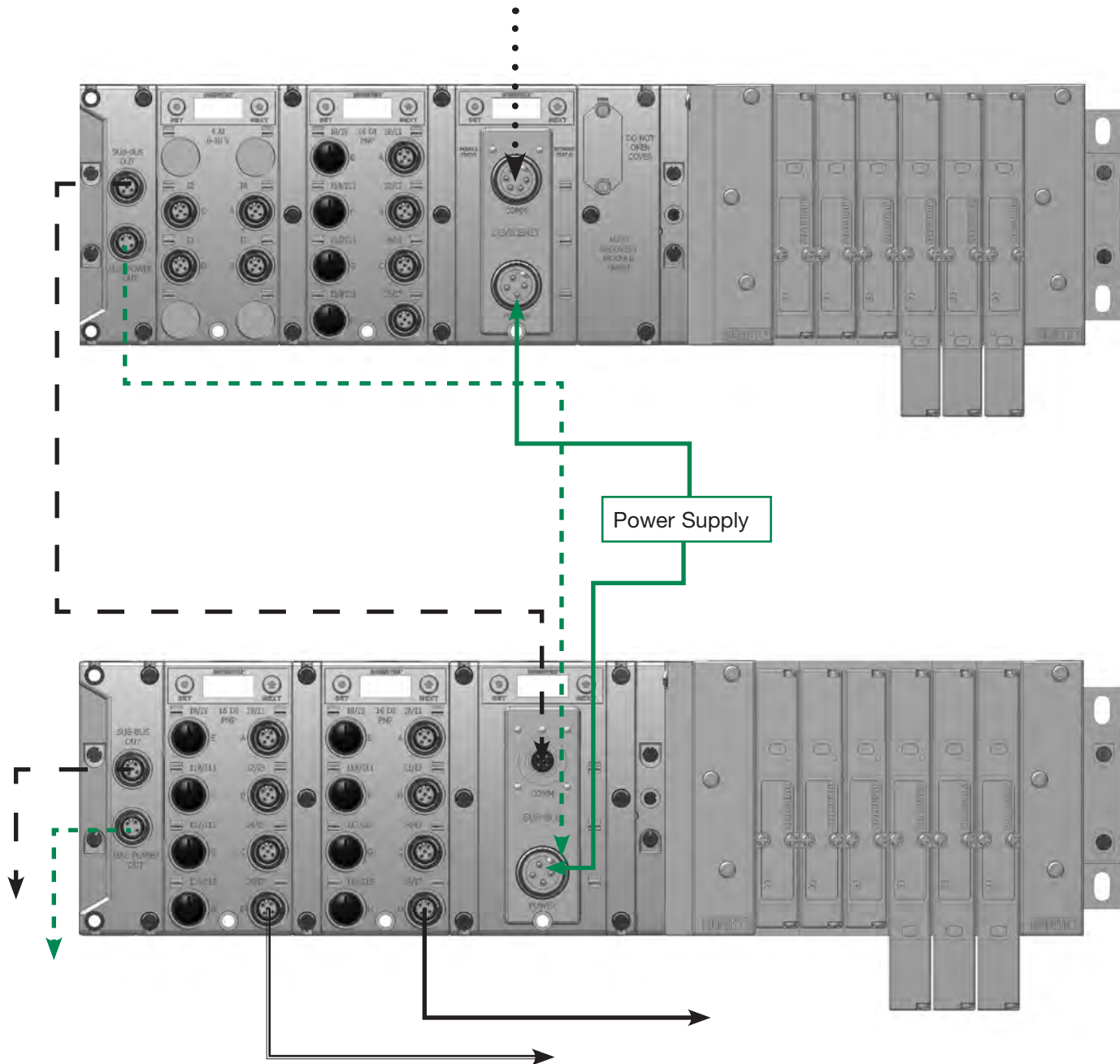

CABLE	DESCRIPTION	EXAMPLE CABLE PART #	PAGE
	Power Cable	MC0405MAC0000000	36
	DeviceNet/CANopen Communication Cable	MC0505MGD0000000	39
	Sub-Bus Cable	TA0501MGDTC0571P	45
	Alternate Sub-Bus Power Option	TA0401MA0MC04000	37
	I/O Field Wireable Connector	TA04F2000000081E	42
	I/O Connector with Molded Cable	TA0405MIE000071P	42

NUMATICS

*World Class Supplier
of Pneumatic Components*

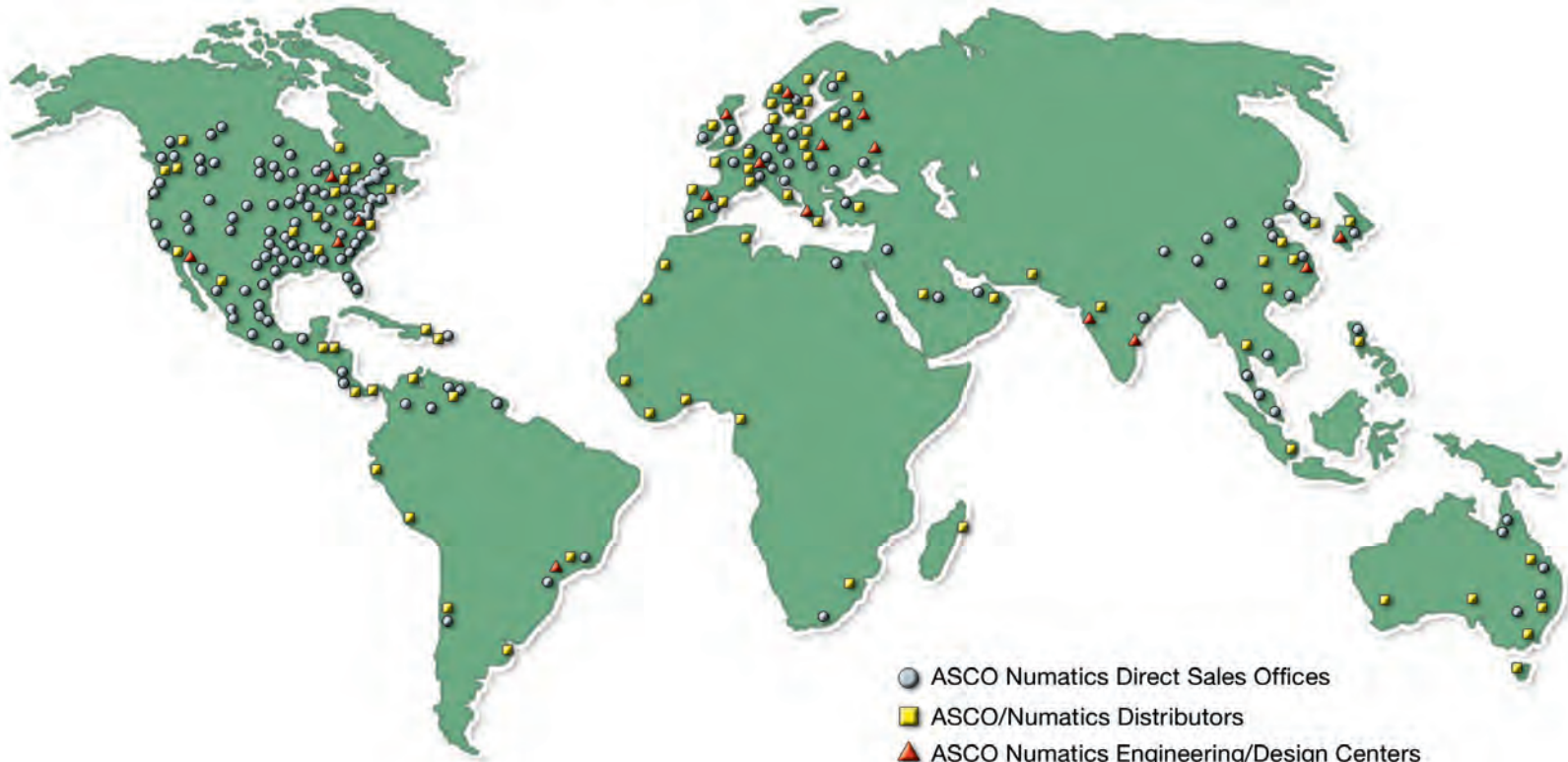

- ASCO Numatics Direct Sales Offices
- ASCO/Numatics Distributors
- ▲ ASCO Numatics Engineering/Design Centers

WORLD HEADQUARTERS

USA

Numatics, Incorporated

46280 Dylan Drive
Novi, Michigan 48377

P: 248-596-3200

F: 248-596-3201

Canada

Numatics, Ltd

P: 519-452-1777

F: 519-452-3995

Mexico

Numatics de Mexico S.A. de C.V.

P: 52-222-284-6176

F: 52-222-284-6179

For a comprehensive listing of all Numatics production and distribution facilities worldwide, visit:

www.numatics.com