

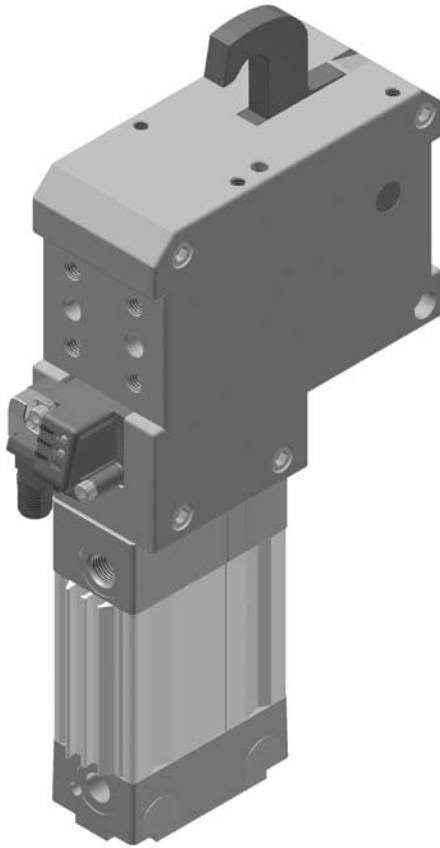

## LTP Series Pneumatic Pin Clamp



### Features

- Vanishing hooks provides low profile
- Multiple pin sizes available
- Unique system prevents weld slag from entering unit
- Long travel of hook designed for increased engagement of sheet metal in oval slots
- Hardened pins, hooks and scrapers for extended life
- Remains locked in closed position even when air pressure is removed
- Pneumatic ports on both sides of the cylinder
- Unique “programmable” all metal sensor with M12 swivel connector

### General Specifications

Weight:

LTP50T: 3.2 Kg (7.1 lbs)

Operating Pressure:

Minimum: 2.75 Bar (40 PSI)

Maximum: 8 Bar (115 PSI)

Operating Temperature: 5° to 45° C (40° to 113°F)

Class Protection: IP54

Maximum Clamping Force

Model Number	4 Bar (58 PSI)	5 Bar (72.5 PSI)
LTP50T	2850 N (640 lbs)	3500 (786 lbs)

### How to Order

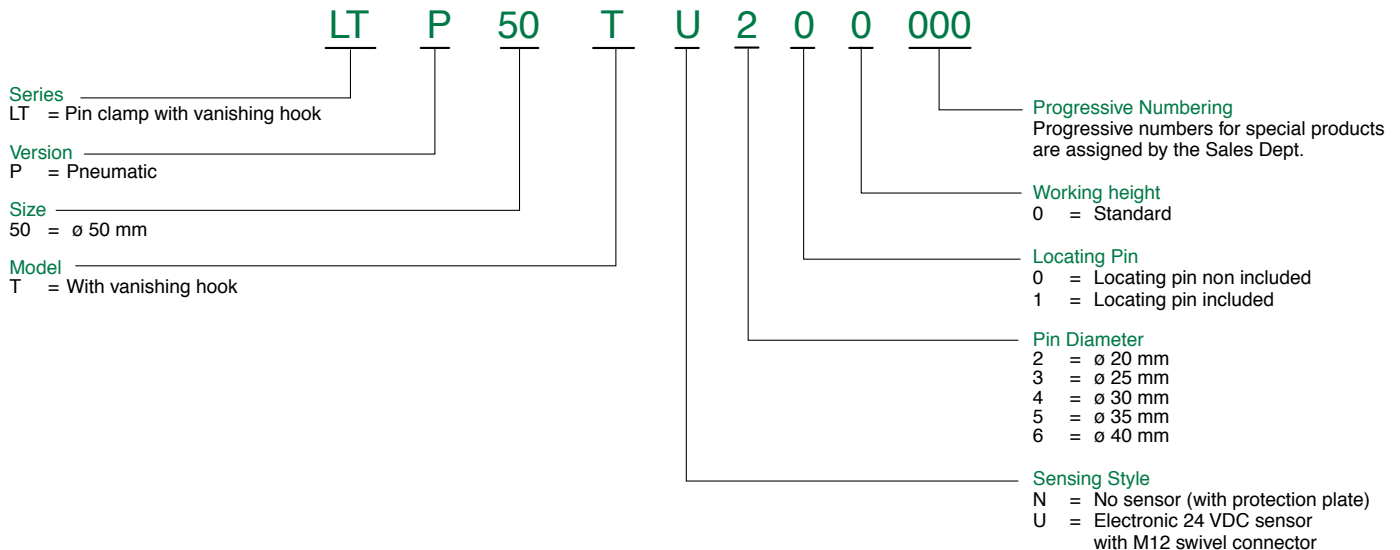



## LTP Series Pneumatic Pin Clamp

### LTP50TU\_OO Pneumatic Pin Clamp with Vanishing Hook

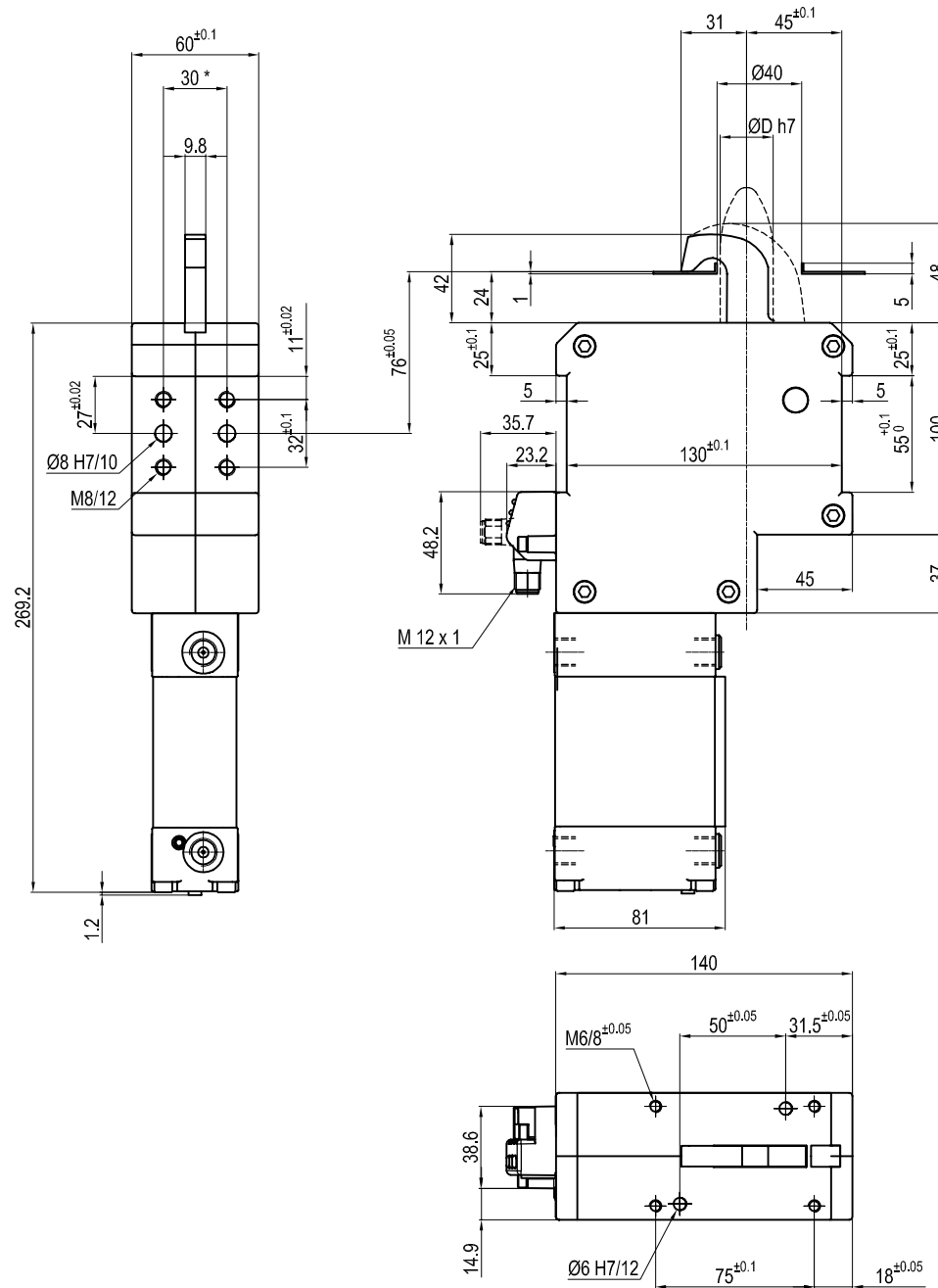

\* : TOLERANCE BETWEEN DOWEL HOLES  $\pm 0.02$ , TO SCREW HOLES  $\pm 0.1$

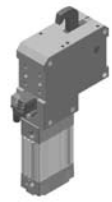

### LTP50TU\_10 Pneumatic Pin Clamp with Vanishing Hook

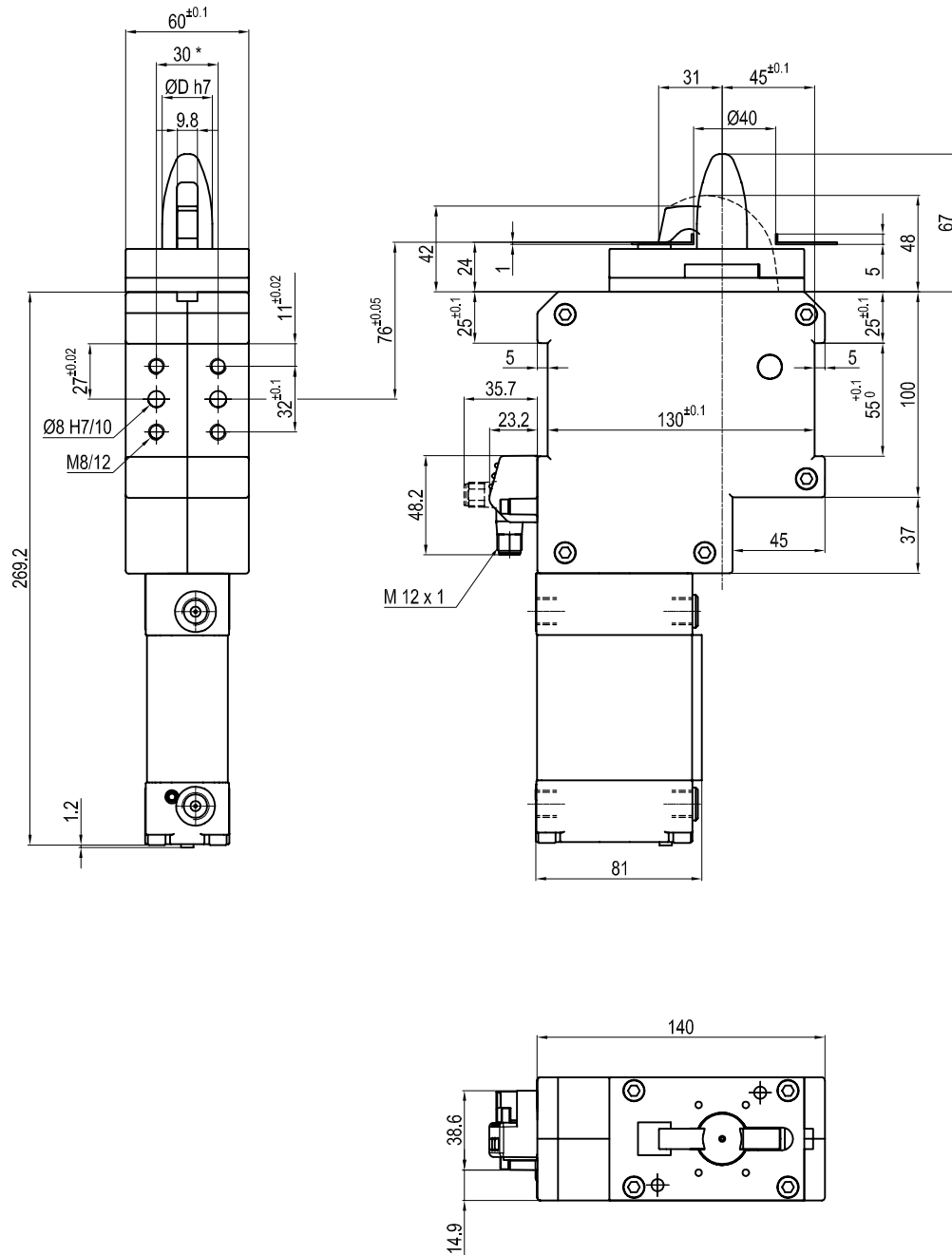

\* : TOLERANCE BETWEEN DOWEL HOLES  $\pm 0.02$ , TO SCREW HOLES  $\pm 0.1$